

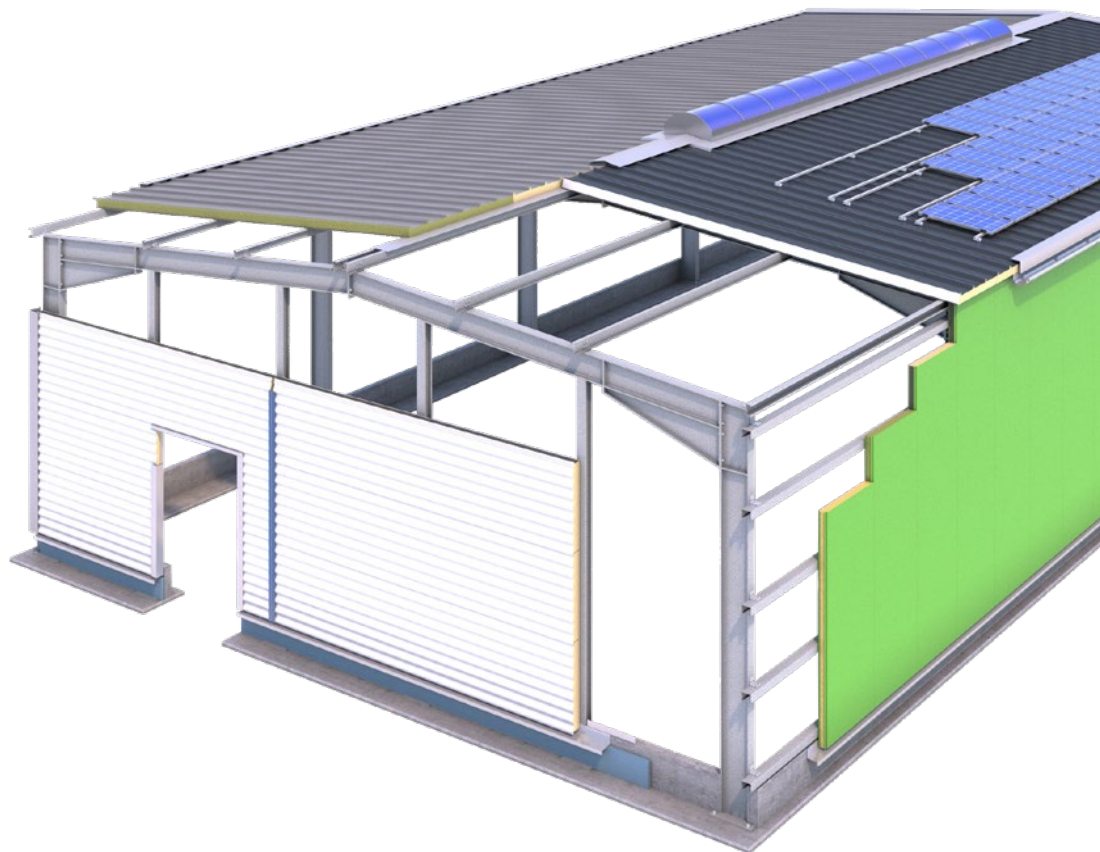

 **meTECNO**
SANDWICH-SYSTEMS | ROOF & WALL

since 1961



WWW.METECNO.DE



MEXICO

COLOMBIA

CHILE

ARGENTINA

PERU

SOUTH
AFRICA

SPAIN

BELGIUM

ITALY

GERMANY

AUSTRIA

BULGARIA

ROMANIA

GREECE



Metecno is an international company specialized in the production of sandwich panels. The group was founded in Italy in 1961.

As a joint-venture of DLW AG in Bietigheim-Bissingen (GER) and Metecno S.p.A. in Tribiano (I) a modern production facility was set up in Jena-Blankenhain to serve the German and European market.

By merging into the internationally oriented Metecno Group and by the know-how developed over the years a constant increase of the market share was secured.

Together with regular product innovation, our technology and production process are always kept on the latest level to ensure the highest possible standard for current and future production.

Over 300 million square meters of sandwich panels have been produced and sold to the most remote countries in the world since Metecno Group was established.

Our most important products include roof and wall panels, perfectly apt for industrial and agricultural use as well as for sports venues and plant construction.

Due to increasing requirements for thermal insulation and fire protection the sandwich construction method has come to stay. The great variety of different profile geometries and vast choice of available colours makes architecturally sophisticated solutions possible.

An extensive range of accessories such as colour-matched flashings, filler blocks, sealing tapes or pilaster strips made of aluminium complement the Metecno product range.



CONTENT



ROOF – SANDWICH PANELS

G4®	polyurethane rigid foam core	05-06
HIPERTEC® ROOF	rock wool core, fire protection	07-08
HIPERTEC® ROOF SOUND	rock wool core, perforated internal sheet, sound protection	09-10

WALL – SANDWICH PANELS

MONOWALL®	polyurethane rigid foam core, visible fixing	11-12
SUPERWALL® ML	polyurethane rigid foam core, hidden fixing	13-14
METFIBER® ECO HF WALL	glass wool core, hidden fixing	15-16
SUPERWALL® HF	rock wool core, hidden fixing, fire protection	17-18
THERMOWALL KOMBI®	polyurethane rigid foam core, visible fixing	19-20
METFIBER® ECO WALL	glass wool core, visible fixing	21-22
METFIBER® ECO WALL SOUND	glass wool core, perforated internal sheet, sound protection	23-24
HIPERTEC® WALL	rock wool core, visible fixing, fire protection	25-26
HIPERTEC® WALL SOUND	rock wool core, perforated internal sheet, sound protection	27-28
H-WALL® 8 P	sinus corrugated wall panel with polyurethane rigid foam core	29-30

Service Portfolio

METECKNO CORNER	31
METCOLOR COATING SYSTEMS	32-33
ACCESSORIES SERVICE	34-35
PILASTER STRIPS	36
CONTACT	37





This sandwich panel with highly heat-insulating CFC- and HCFC-free polyurethane rigid foam core is suited best for today's requirements for thermal insulation and moisture protection. Besides that it may also be used as a visual design element for facades. The sloped element joint with integrated sealing closes during installation without any additional working steps. Thus, one single operation produces a reliable connection without any ther-

mal bridge. The G4® panel ensures a very high installation speed and is therefore THE product of choice for many professional installation companies. Depending on the application, a minimum roof slope of $\geq 5^\circ$ is recommended. More information is available in the download area www.en.metecno.de.

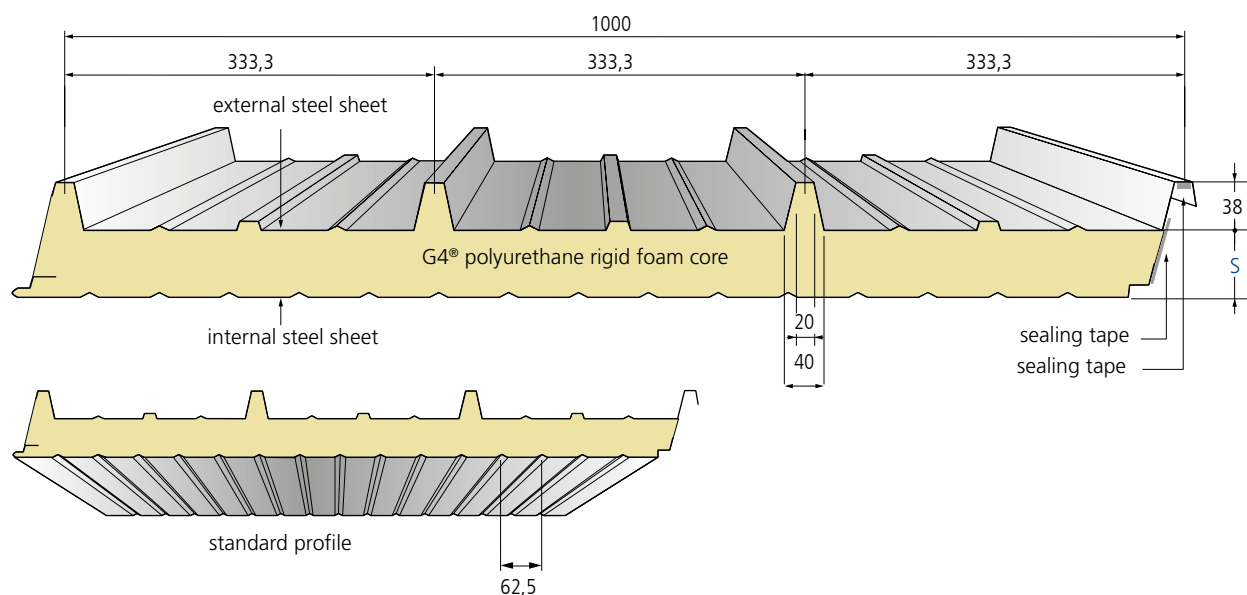

type of element	core thickn. s	total-thickn. D	external steel sheet t_N	internal steel sheet t_N	weight kg / m^2	thermal resistance R	thermal conductivity	
							[ψ - joint effect]	
	mm	mm	mm	mm		$m^2 K / W$	U without ψ	U with ψ
G4®	30	68	0,60	0,45	11,1	1,21	0,773	0,798
	40	78	0,60	0,45	11,5	1,62	0,584	0,598
	50	88	0,60	0,45	11,9	2,04	0,489	0,499
	60	98	0,60	0,45	12,3	2,46	0,393	0,399
	80	118	0,60	0,45	13,1	3,29	0,296	0,299
	100	138	0,60	0,45	13,9	4,12	0,237	0,240
	120	158	0,60	0,45	14,7	4,96	0,198	0,199
	150	188	0,60	0,45	15,9	6,20	0,159	0,160



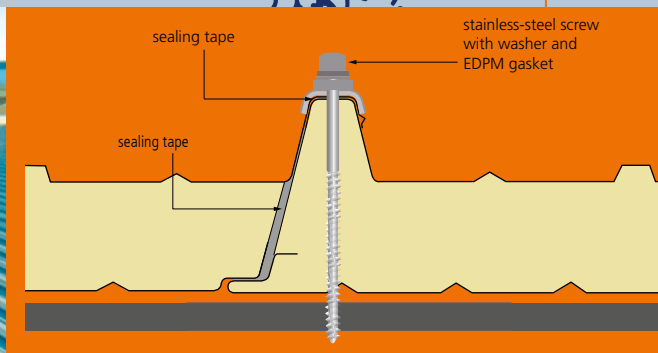

PRODUCTION AND LABELING

Production according to applicable European Building Product Regulation as per sandwich norm DIN EN 14509 label-marking in accordance with EC certificate of conformity 0769-CPR-VAS-00420

APPLICATION APPROVAL

Current approvals, certificates and general building permits at www.en.metecno.de/service.

REACTION TO FIRE

Building material classified as B-s2,d0 low flammable according to DIN EN 13501-1 and DIN 18234 G4@ roof panels are rated as "hard roofing" - resistant to airborne fire and radiating heat according to DIN EN 14509
Approval for d=100 according DIN 18234-1 structural fire protection of large-scale roofs

THERMAL CONDUCTIVITY

$\lambda = 0.024 \text{ W / m.K}$ according to DIN 4108 and DIN EN 13165 Insulation values are regularly monitored by external bodies and may be applied without any further reduction.

SOUND INSULATION

$R_w \geq 25 \text{ dB}$

STANDARD COATING

External steel sheet: 25 μm polyester

Internal steel sheet: $\approx 15 \mu\text{m}$ thin coating (DU)

For standard colours and different coating systems please refer to our colour chart

NON-PENETRATIVE PHOTOVOLTAIC MOUNTING

Fixation of new/modified solar fasteners (Clamp Fit, Single Fix-V) on G4-roof panels with continuous core thickness $\geq 40 \text{ mm}$ as certified all-in-one system with general approval "allgemeiner Bauartgenehmigung (Z-10.4-583)"

STANDARD LENGTHS

> 2,00 m to 25,00 m, greater lengths on request

CORROSION PROTECTION

Tested to DIN EN 10169
External sheet: Class RC3
Internal sheet: Class RC2

According to DIN EN ISO 12944-2:

External sheet: corrosivity category C3 corresponding to average duration of protection for urban and industrial environments with moderate exposure to sulphur dioxide

Internal sheet: corrosivity category C2 for dry indoor rooms and buildings with occasional probability of minor condensation

Other coating systems are available for more sophisticated demands such as for buildings near the sea, farm buildings with high ammonia exposure or moist rooms

STANDARD STEEL SHEETS

Hot-dip galvanized steel, grade S 320 GD+ Z 275 according to DIN EN 10346

TABLE OF SPANS

Please visit our website www.en.metecno.de

PACKAGING

External sheet provided with removable protective film, panel packages wrapped with banded plastic foil to protect from soiling



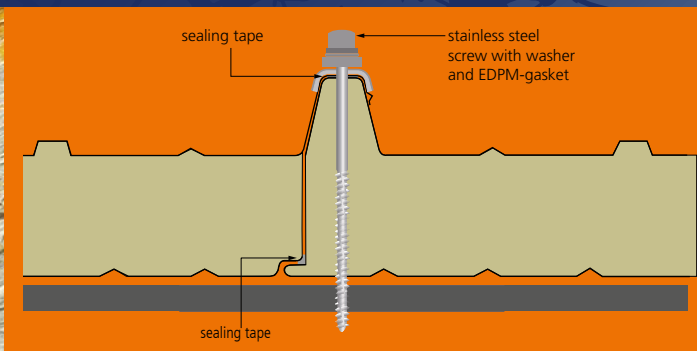

This sandwich panel with non-combustible insulation core made of rock wool meets today's high demands for fire protection. According to the guidelines for industrial construction, non-combustible insulation materials are obligatory, particularly for large-surface and multi-storey buildings. For core thickness of 100 mm and higher a fire resistance up to 90 minutes can be reached. Additionally Hipertec® Roof panels show exceptional acoustic

insulation behaviour as well. Thanks to the high quality of the production process the interlocking of the joint is perfect and panels up to 25 meters length can be installed rapidly.

To protect the rock wool core from moisture a cut back and protective flashing at the eaves are recommended. More information is available in the download area www.en.metecno.de.

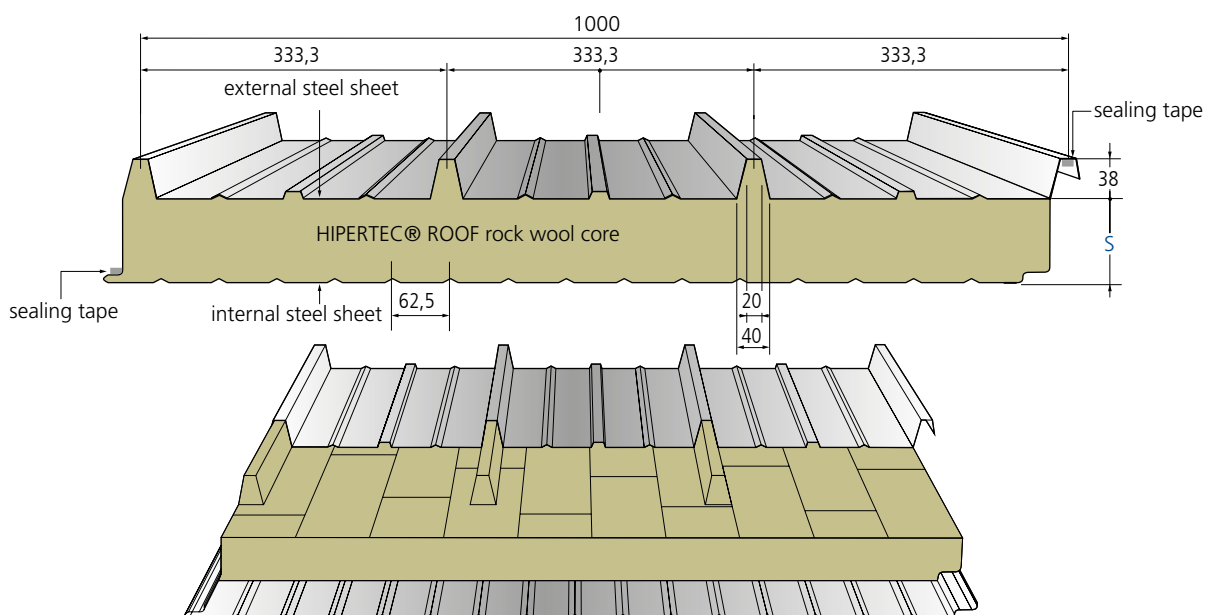

different internal profiles on request, dimensions in mm

type of element	core-thickn.s mm	total-thickn. D mm	external steel sheet tN mm	internal steel sheet tN mm	weight kg / m ²	thermal resistance R m ² K / W	thermal conductivity (Ψ - joint effect)	
							U w/o Ψ W / m ² K	U with Ψ W / m ² K
HIPERTEC® ROOF	60	98	0,60	0,45	16,8	1,34	0,705	0,707
	80	118	0,60	0,45	19,0	1,79	0,534	0,535
	100	138	0,60	0,45	21,2	2,25	0,429	0,430
	120	158	0,60	0,45	23,4	2,70	0,359	0,360
	150	188	0,60	0,45	26,7	3,39	0,289	0,289
	200	238	0,60	0,45	32,1	4,52	0,217	0,218





PRODUCTION AND LABELING

Production according to applicable European Building Product Regulation as per sandwich norm DIN EN 14509 labeling in accordance with EC certificate of conformity 0769-CPR-VAS-00420

APPLICATION APPROVAL

Current approvals, certificates and general building permits at www.en.metecno.de/service.

REACTION TO FIRE

Building material classified as A2-s1,d0 non-combustible according to DIN EN 13501-1; Hipertec® Roof panels are rated as "hard roofing" - resistant to airborne fire and radiating heat according to DIN EN 14509

FIRE RESISTANCE

German building compliance certificate Dibt Application Approval Z-19.52-2096 (see table below)

THERMAL CONDUCTIVITY

$\lambda = 0.044 \text{ W / m.K}$ according to DIN 4108 and DIN EN 13162 The insulation values are regularly monitored by external bodies and may be applied without any further reduction.

SOUND INSULATION

$R_w \geq 29 - 32 \text{ dB}$

SUPPORT WIDTHS FOR FIRE RESISTANCE CAPABILITY ACCORDING TO FIRE RESISTANCE APPROVAL Z-19.52-2096

core thickn. s	fire-retardant REI30	highly fire retardant REI60	fire resistant REI90
mm	mm	mm	mm
≥ 100	3000	3000	3000

Please note that the maximum spans for roofs are primarily determined by snow and wind loads.

STANDARD COATING

External steel sheet: 25 μm polyester
Internal steel sheet: $\approx 15 \mu\text{m}$ thin coating (DU)
For standard colours and different coating systems please refer to our colour chart

STANDARD LENGTHS

> 2,00 m to 25,00 m, greater lengths on request

CORROSION PROTECTION

Tested according to DIN EN 10169:

External sheet: Class RC3

Internal sheet: Class RC2

According to DIN EN ISO 12944-2: External sheet: corrosivity category C3 corresponding to average protection duration and industrial environments with moderate exposure to sulphur dioxide

Internal sheet: corrosivity category C2 for dry indoor rooms and buildings with occasional probability of minor condensation

Other coating systems are available for more sophisticated demands such as for buildings near the sea, farm buildings with high ammonia exposure or moist rooms

STANDARD STEEL SHEETS

Hot-dip galvanized steel, grade S 320 GD + Z275 according to DIN EN 10346

TABLE OF SPANS

Please visit our website www.en.metecno.de

PACKAGING

External sheet provided with removable protective film, panel packages wrapped with banded plastic foil to protect from soiling.





With its perforated internal sheet the Hipertec® Roof Sound panel contributes drastically to the improvement of sound insulation and sound absorption where applied. Designed particularly for ceiling application it may also be used as external roof in specific cases, including unheated premises. However for heated or moist are-

as the use of Hipertec® Roof Sound panels is not recommended since the internal sheet has no vapour barrier. This system patented by Metecno applies a special fleece as trickle protection between the internal sheet and the mineral wool core. More information is available in the download area www.en.metecno.de.

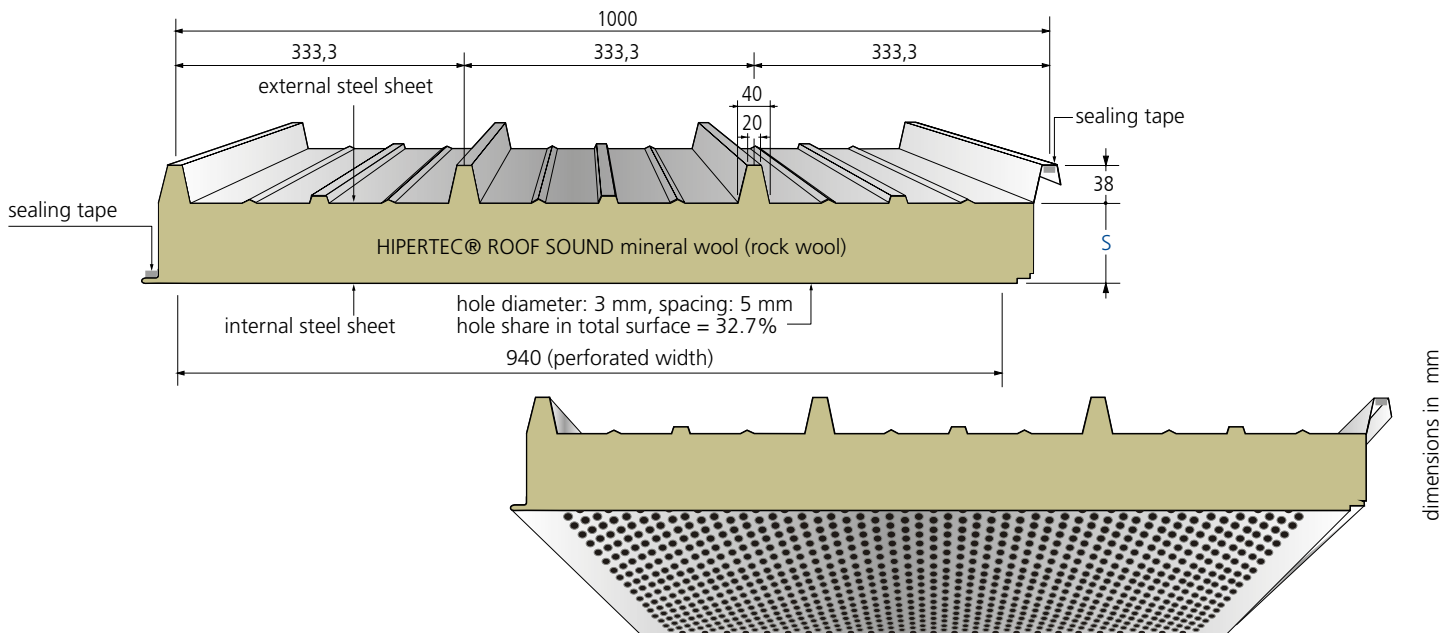

type of element	core-thickn.s mm	total-thickn. D mm	external steel sheet tN mm	internal steel sheet tN mm	weight kg / m ²	thermal resistance R m ² K / W	thermal conductivity (Ψ - joint effect)	
							U w/o Ψ W / m ² K	U with Ψ W / m ² K
HIPERTEC® ROOF SOUND	60	98	0,60	0,60	16,4	1,34	0,705	0,707
	80	118	0,60	0,60	18,6	1,79	0,534	0,535
	100	138	0,60	0,60	20,8	2,25	0,429	0,430
	120	158	0,60	0,60	23,0	2,70	0,359	0,360
	150	188	0,60	0,60	25,2	3,39	0,289	0,289
	200	238	0,60	0,60	27,4	4,52	0,217	0,218

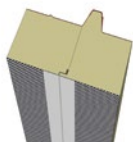

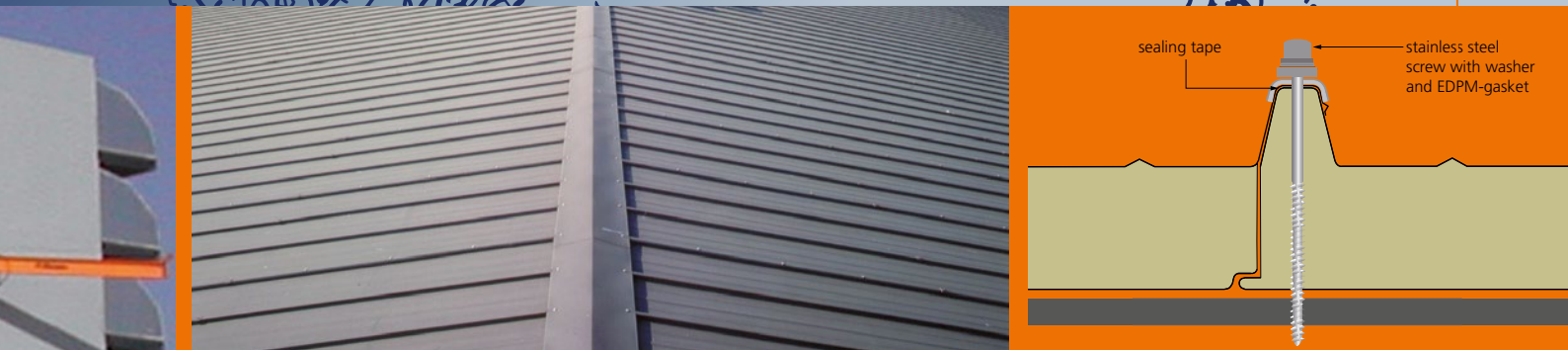

THERMAL CONDUCTIVITY

$\lambda = 0.044 \text{ W / m.K}$ according to DIN 4108 and DIN EN 13162
 The insulation values are regularly monitored by external bodies and may be applied without any further reduction.

STANDARD COATING

External and internal steel sheet: 25 μm polyester

STANDARD LENGTHS

> 2,00 m to 25,00 m, greater lengths on request

PACKAGING

External and internal sheets provided with removable protective film, panel packages wrapped with banded plastic foil to protect from soiling

SOUND INSULATION

Rated sound insulation $R_w \geq 33 \text{ dB}$

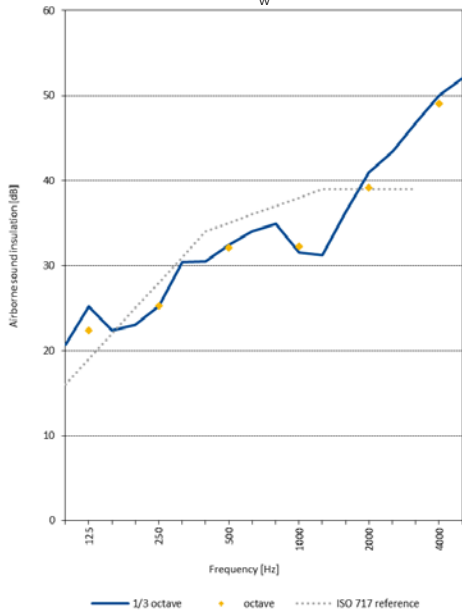

CORROSION PROTECTION

Tested according to DIN EN 10169: External sheet: Class RC3
 According to DIN EN ISO 12944-2: External sheet: corrosivity category C3 corresponding to average protection duration for urban and industrial environments with moderate exposure to sulphur dioxide

REACTION TO FIRE

Hipertec® Roof panels are rated as "hard roofing" - resistant to airborne fire and radiating heat according to DIN 4102-4.

SOUND ABSORPTION

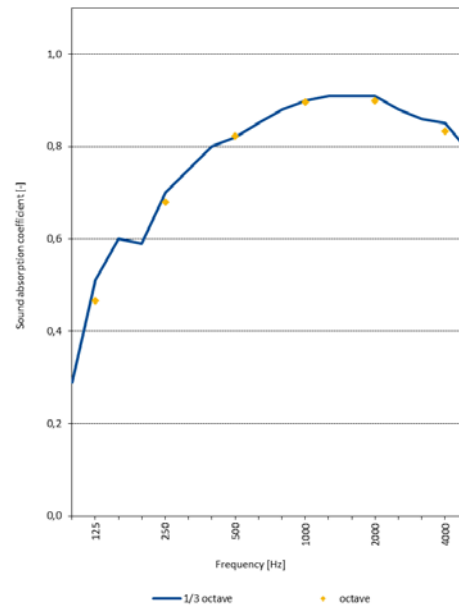

frequency Hz	thickness mm	125	250	500	1000	2000	4000
α_s	100	0,47	0,68	0,82	0,90	0,90	0,83





The Monowall® panel with polyurethane insulation core is suitable for both vertical and horizontal installation. Its special surface profile facilitates the installation of the panel without the risk of bulging. The appearance of the external side benefits distinctly from the screw head applied in the recess of the profile.

A non-displaceable longitudinal sealing strip produces a joint resistant to driving rain and wind. The organic coating of the steel sheet ensures efficient protection against all kinds of weather. Additional coating systems are available for advanced application. More information is available in the download area www.en.metecno.de.

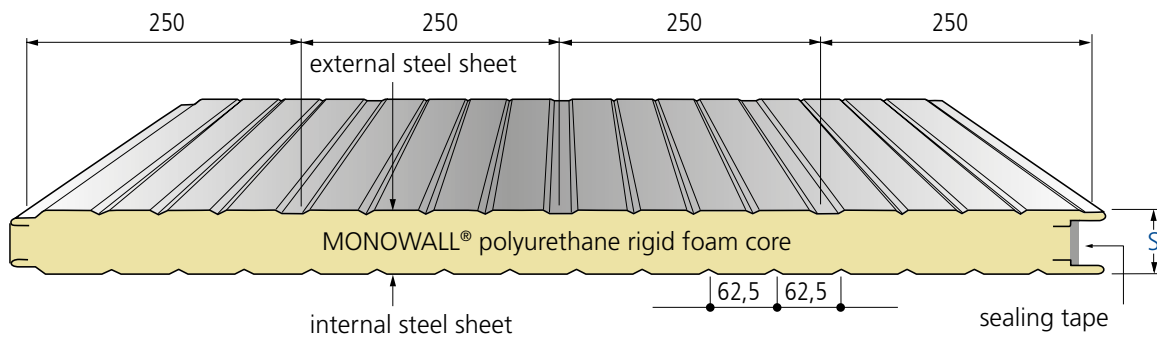

different internal profiles on request, dimensions in mm

type of element	core thickn. s mm	external steel sheet t _N mm	Internal steel sheet t _N mm	weight kg / m ²	thermal resistance R m ² K / W	thermal conductivity (ψ - joint effect)	
						U w/o ψ W / m ² K	U with ψ W / m ² K
 MONOWALL®	40	0,60	0,45	10,7	1,62	0,606	0,643
	50	0,60	0,45	11,1	2,04	0,504	0,531
	60	0,60	0,45	11,5	2,46	0,402	0,415
	80	0,60	0,45	12,3	3,29	0,301	0,308
	100	0,60	0,45	13,1	4,12	0,241	0,245
	120	0,60	0,45	13,9	4,96	0,201	0,204

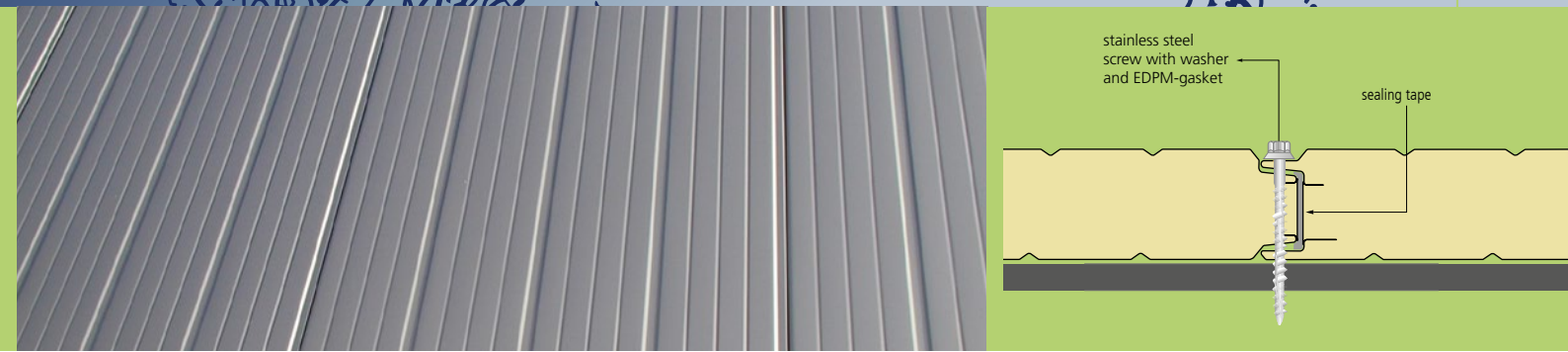

PRODUCTION AND LABELING

Production according to applicable European Building Product Regulation as per sandwich norm DIN EN 14509 label-marking in accordance with EC certificate of conformity 0769-CPR-VAS-00420

APPLICATION APPROVAL

Current approvals, certificates and general building permits at www.en.metecno.de/service.

REACTION TO FIRE

Building material classified as B-s2,d0 low flammable according to DIN EN 13501-1

THERMAL CONDUCTIVITY

$\lambda = 0.024 \text{ W / m.K}$ according to DIN 4108 and DIN EN 13165
The insulation values are regularly monitored by external bodies and may be applied without any further reduction.

SOUND INSULATION

$R_w \geq 25 \text{ dB}$

STANDARD COATING

External steel sheet: 25 μm polyester

Internal steel sheet: $\approx 15 \mu\text{m}$ thin coating (DU)

For standard colours and different coating systems please refer to our colour chart

STANDARD LENGTHS

> 2,00 m to 25,00 m, greater lengths on request

CORROSION PROTECTION

According to DIN EN 10169:

External sheet: Class RC3

Internal sheet: Class RC2

According to DIN EN ISO 12944-2:

External sheet: corrosivity category C3 corresponding to average duration of protection for urban and industrial environments with moderate exposure to sulphur dioxide
Internal sheet: corrosivity category C2 for dry indoor rooms and buildings with occasional probability of minor condensation

Other coating systems are available for more sophisticated demands such as for buildings near the sea, farm buildings with high ammonia exposure or moist rooms

STANDARD STEEL SHEETS

Hot-dip galvanized steel, grade S 320 GD+ Z 275 according to DIN EN 10346

TABLE OF SPANS

Please visit our website www.en.metecno.de

PACKAGING

External sheet provided with removable protective film, panel packages wrapped with banded plastic foil to protect from soiling





The Superwall® ML sandwich panel with microprofiled external steel sheet and joint-geometry for hidden fixing suits best to meet today's sophisticated requirements for high-quality facades. The shear-resistant connection of the cover sheets together with the compressive strength of the insulation core make large support widths possible for both vertical and horizontal installation. For buildings exposed to high wind suction, horizontal single span installation is recommended as well as the use of visible fixing screws covered by pilaster pro-

files. A non-displaceable sealing strip foamed into the longitudinal joint procures resistance to driving rain and wind. Together with the organic coating of the steel sheets this ensures efficient protection against all kinds of weather. For advanced applications additional coating systems are available. More information is available in the download area www.en.metecno.de.

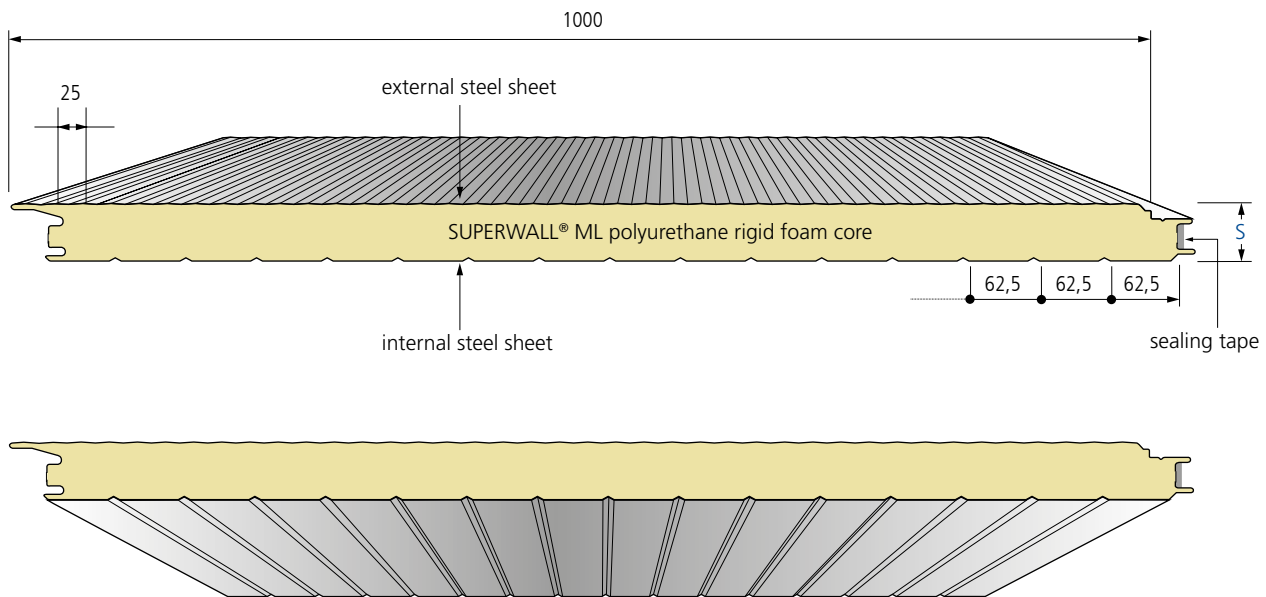

different internal profiles on request, dimensions in mm

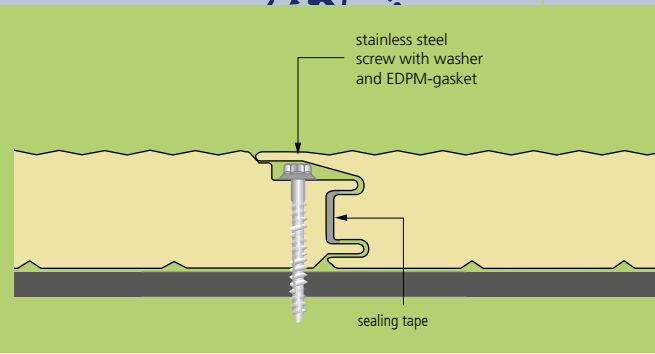

PRODUCTION AND LABELING

Production according to applicable European Building Product Regulation as per sandwich norm DIN EN 14509 label-marking in accordance with EC certificate of conformity 0769-CPR-VAS-00420

APPLICATION APPROVAL

Current approvals, certificates and general building permits at www.en.metecno.de/service.

REACTION TO FIRE

Building material classified as B-s2,d0 low flammable according to DIN EN 13501-1

THERMAL CONDUCTIVITY

$\lambda = 0.024 \text{ W / m.K}$ according to DIN 4108 and DIN EN 13165 The insulation values are regularly monitored by external bodies and may be applied without any further reduction

SOUND INSULATION

$R_w \geq 25 \text{ dB}$

STANDARD COATING

External steel sheet: 25 μm polyester

Internal steel sheet: $\approx 15 \mu\text{m}$ thin coating (DU)

For standard colours and different coating systems please refer to our colour chart

STANDARD LENGTHS

> 2.00 m to 25.00 m, greater lengths on request

STANDARD STEEL SHEETS

Hot-dip galvanized steel, grade S 320 GD+ Z 275 according to DIN EN 10346

CORROSION PROTECTION

According to DIN EN 10169: External sheet: Class RC3 Internal sheet: Class RC2

According to DIN EN ISO 12944-2:

External sheet: corrosivity category C3 corresponding to average duration of protection for urban and industrial environments with moderate exposure to sulphur dioxide

Internal sheet: corrosivity category C2 for dry indoor rooms and buildings with occasional probability of minor condensation.

Other coating systems are available for more sophisticated demands such as for buildings near the sea, farm buildings with high ammonia exposure or moist rooms

TABLE OF SPANS

Please visit our website www.en.metecno.de

PACKAGING

External sheet provided with removable protective film, panel packages wrapped with banded plastic foil to protect from soiling

INTERLOCKING JOINT COMPATIBILITY WITH METFIBER® ECO HF WALL & SUPERWALL® HF

type of element	core thckn. s	external steel sheet	internal steel sheet	weight	thermal resistance	thermal conductivity	
						[Ψ – joint effect]	
	mm	mm	mm	kg / m ²	R	U w/o Ψ	U with Ψ
		tn	tn		m ² K / W	W / m ² K	W / m ² K
SUPERWALL® ML	60	0,60	0,45	11,8	2,46	0,400	0,442
	80	0,60	0,45	12,6	3,29	0,300	0,317
	100	0,60	0,45	13,4	4,12	0,240	0,250
	120	0,60	0,45	14,2	4,96	0,200	0,207
	150	0,60	0,45	15,4	6,20	0,160	0,164
	160*	0,60	0,45	15,8	6,63	0,147	0,150

* approval pending





The Metfiber® Eco HF Wall panel with glass wool core and joint geometry for hidden fixing fulfils all the requirements for non-combustible building materials and is suited for both vertical and horizontal installation. The glass wool used in this product consists of 80% recycled material, thus contributing significantly to the saving of natural resources and making the product an ecological building material. The deadweight of the panel is distinctly lower than that of conventional sandwich panels with rock wool insulation core, hence enabling an easier, faster installation and cost reduc-

tion, especially for larger panels. For buildings exposed to high wind suction horizontal single span installation is recommended as well as the use of visible fixing screws covered by pilaster profiles. Due to the large number of combinations with other panels from our portfolio with polyurethane- or rock wool insulation core, it is possible to reach fire, acoustic and thermal requirements at once without any visual impact. More information is available in the download area www.en.metecno.de.

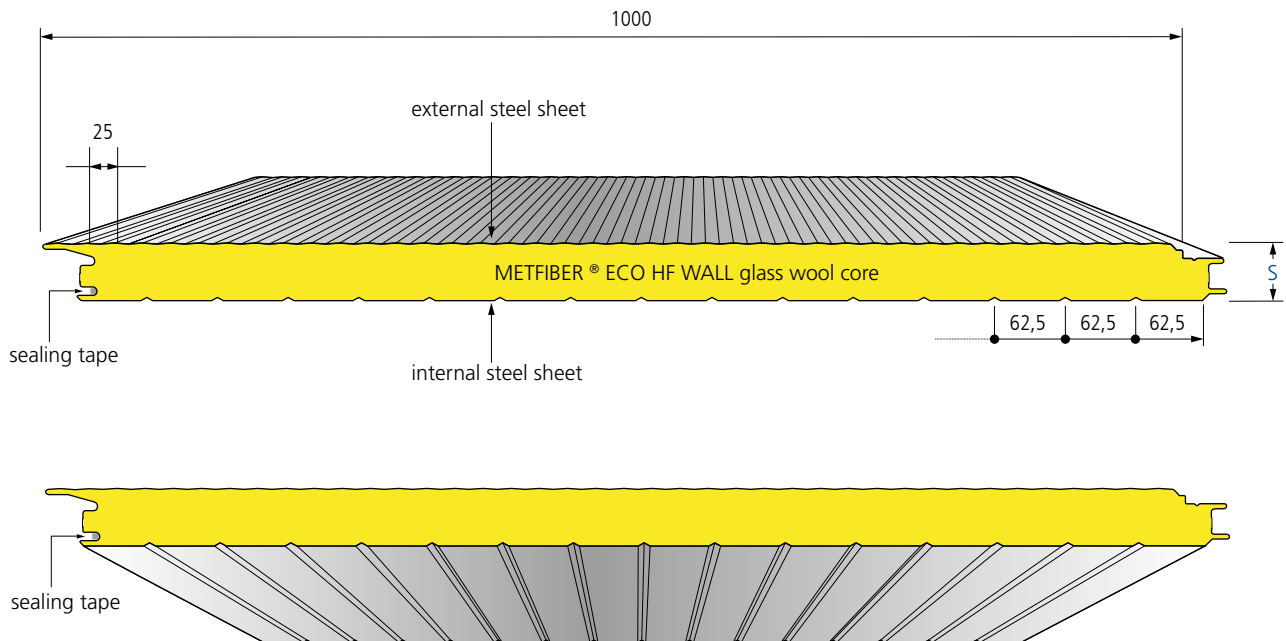

different internal profiles on request, dimensions in mm

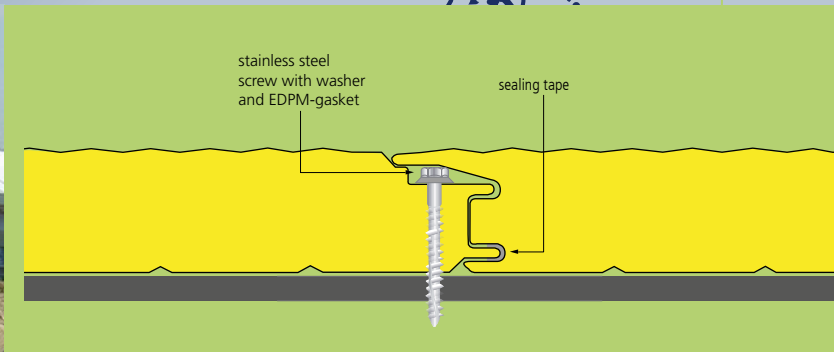

PRODUCTION AND LABELING

Production according to applicable European Building Product Regulation as per sandwich norm DIN EN 14509 label-marking in accordance with EC certificate of conformity 0769-CPR-VAS-00420

APPLICATION APPROVAL

Current approvals, certificates and general building permits at www.en.metecno.de/service.

REACTION TO FIRE

Building material classified as A2-s1,d0 non-combustible according to DIN EN 13501-1; insulation core made of glass wool

THERMAL CONDUCTIVITY

$\lambda = 0.039 \text{ W / m.K}$ according to DIN 4108 and DIN EN 13162 The insulation values are regularly monitored by external bodies and may be applied without any further reduction

STANDARD COATING

External and internal steel sheet: 25 μm polyester
For standard colours and different coating systems please refer to our colour chart

STANDARD LENGTHS

> 2.00 m to 25.00 m, greater lengths on request

CORROSION PROTECTION

According to DIN EN 10169:

External and Internal sheets: Class RC3

According to DIN EN ISO 12944-2:

External and internal sheets: corrosivity category C3

corresponding to average duration of protection for urban and industrial environments with moderate exposure to sulphur dioxide
Other coating systems are available for more sophisticated demands such as for buildings near the sea, farm buildings with high ammonia exposure or moist rooms

STANDARD STEEL SHEETS

Hot-dip galvanized steel, grade S 320 GD + Z275 according to DIN EN 10346

TABLE OF SPANS

Please visit our website www.en.metecno.de

PACKAGING

External sheets provided with removable protective film, panel packages wrapped with banded plastic foil to protect from soiling

INTERLOCKING JOINT COMPATIBILITY WITH SUPERWALL® ML & SUPERWALL® HF

type of element	core thickn. s	external steel sheet tn	internal steel sheet tn	weight kg / m ²	thermal resistance R m ² K / W	thermal conductivity [Ψ – joint effect]	
						U w/o Ψ W / m ² K	U with Ψ W / m ² K
 METFIBER® ECO HF WALL	100	0,60	0,60	17,16	2,54	0,385	0,400
	120	0,60	0,60	18,46	3,05	0,322	0,331
	150	0,60	0,60	20,14	3,82	0,258	0,264
	200	0,60	0,60	23,66	5,10	0,194	0,197
	240*	0,60	0,60	26,26	6,12	0,162	0,164

* no approval / on request





The Superwall® HF sandwich panel with microprofiled external steel sheet, non-combustible rock wool core and joint geometry for hidden fixing is suited best to meet today's sophisticated requirements for high-quality facades. The panels can be placed vertically or horizontally and, depending on the insulation thickness, may reach a fire resistance up to 90 minutes. Additionally Superwall® HF panels show excellent acoustic insulation behaviour as well. For buildings exposed to high wind suction horizontal single span in-

stallation is recommended as well as the use of visible fixing screws covered by pilaster profiles. Due to the large number of combinations with other panels from our portfolio with polyurethane or glass wool insulation core, it is possible to reach fire, acoustic and thermal requirements at once without any visual impact. More information is available in the download area www.en.metecno.de.

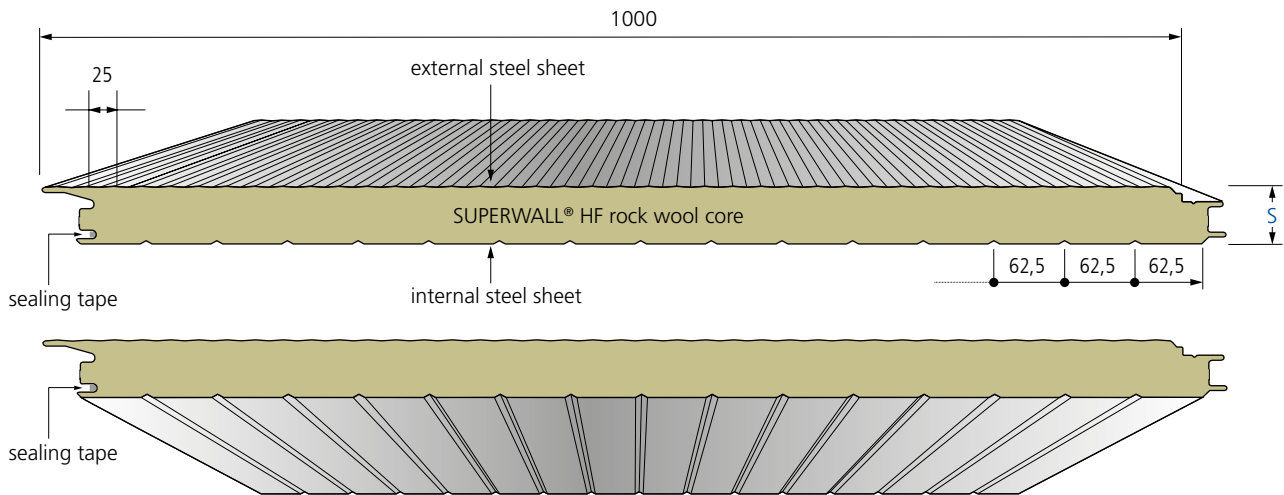

different internal profiles on request, dimensions in mm

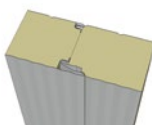
type of element	core thickn. s mm	external steel sheet t _N mm	Inner steel sheet t _N mm	weight kg / m ²	thermal resistance R m ² K / W	thermal conductivity [Ψ - joint effect]	
						U w/o Ψ W / m ² K	U with Ψ W / m ² K
 SUPERWALL® HF	60	0,60	0,60	17,0	1,34	0,713	0,778
	80	0,60	0,60	19,5	1,79	0,539	0,566
	100	0,60	0,60	21,7	2,25	0,433	0,449
	120	0,60	0,60	23,9	2,70	0,362	0,372
	150	0,60	0,60	27,2	3,37	0,290	0,297
	200	0,60	0,60	32,7	4,52	0,218	0,222
	240	0,60	0,60	37,1	5,43	0,182	0,185

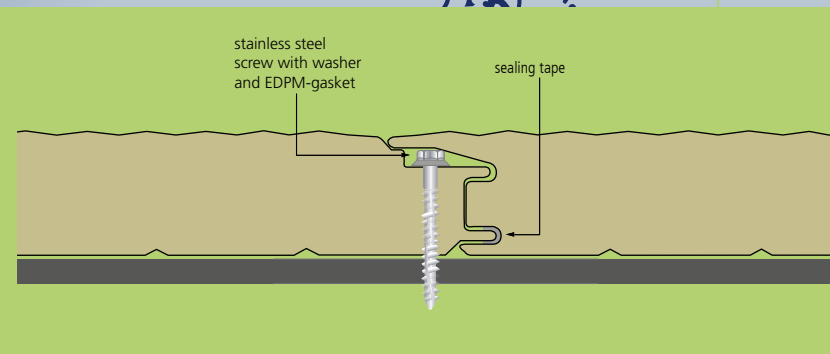

PRODUCTION AND LABELING

Production according to applicable European Building Product Regulation as per sandwich norm DIN EN 14509 label-marking in accordance with EC certificate of conformity 0769-CPR-VAS-00420

APPLICATION APPROVAL

Current approvals, certificates and general building permits at www.en.metecno.de/service.

REACTION TO FIRE

Building material classified as A2-s1, d0 non-combustible according to DIN EN 13501-1, rock wool core A1, non-combustible, melting point > 1000°C

FIRE RESISTANCE

German building compliance certificate DIBt Application Approval Z-19.52-2096 (see table below)

THERMAL CONDUCTIVITY

$\lambda = 0.044 \text{ W / m.K}$ according to DIN 4108 and DIN EN 13162
The insulation values are regularly monitored by external bodies and may be applied without any further reduction.

SOUND INSULATION

$R_w \geq 30 \text{ dB}$

TABLE OF SPANS

Please visit our website www.en.metecno.de

SUPPORTING WIDTHS FOR ACHIEVING FIRE RESISTANCE ACCORDING GERMAN FIRE RESISTANCE APPROVAL/BRAND-SCHUTZZULASSUNG Z-19.52-2096

panel thickn. s	vertical installation			horizontal installation			SINGLE-SPAN INSTALLATION
	fire retardant EI30	highly fire retardant EI60	fire resistant EI90	fire retardant EI30	highly fire retardant EI60	fire resistant EI90	
mm	mm	mm	mm	mm	mm	mm	
100	4000	3000	-	-	-	-	
≥ 120	4000	4000	3000	5000	5000	5000	
			panel thickn. s	vertical inst. fire retardant EI30	highly fire retardant EI60	fire resistant EI90	
MULTIPLE-SPAN INSTALLATION			mm	mm	mm	mm	
maximum spans of exterior walls additionally influenced by wind load			≥150	3500	3500	-	

STANDARD COATING

External and internal steel sheet: 25 µm polyester

For standard colours and different coating systems please refer to our colour chart

STANDARD LENGTHS

> 2.00 m up to 25.00 m, greater lengths on request

CORROSION PROTECTION

According to DIN EN 10169:

External and internal sheets: Class RC3

According to DIN EN ISO 12944-2: External and internal sheets: corrosivity category C3 corresponding to average duration of protection for urban and industrial environments with moderate exposure to sulphur dioxide Other coating systems are available for more sophisticated demands such as for buildings near the sea, farm buildings with high ammonia exposure or moist rooms

STANDARD STEEL SHEETS

Hot-dip galvanized steel, grade S 320 GD+ Z 275 according to DIN EN 10346

PACKAGING

External sheets provided with removable protective film, panel packages wrapped with banded plastic foil to protect from soiling

INTERLOCKING JOINT COMPATIBILITY WITH SUPERWALL® ML &

METFIBER® ECO HF WALL





The Thermowall Kombi® panel with CFC and HCFC free polyurethane insulation core was developed as combination element matching the HIPERTEC® Wall panel with both panels having the same joint geometry. Thus, walls with high demands for thermal insulation (Thermowall Kombi®) can be combined with walls having high fire resistance requirements (Hipertec® Wall) without any visual impact. Besides, the symmetric profile geometry of external

and internal sheet makes this product an excellent partition wall. A non-displaceable longitudinal sealing strip produces a joint resistant to driving rain and wind. The organic coating of the steel sheet ensures efficient protection against all kinds of weather. Additional coating systems are available for advanced application. More information is available in the download area www.en.metecno.de.

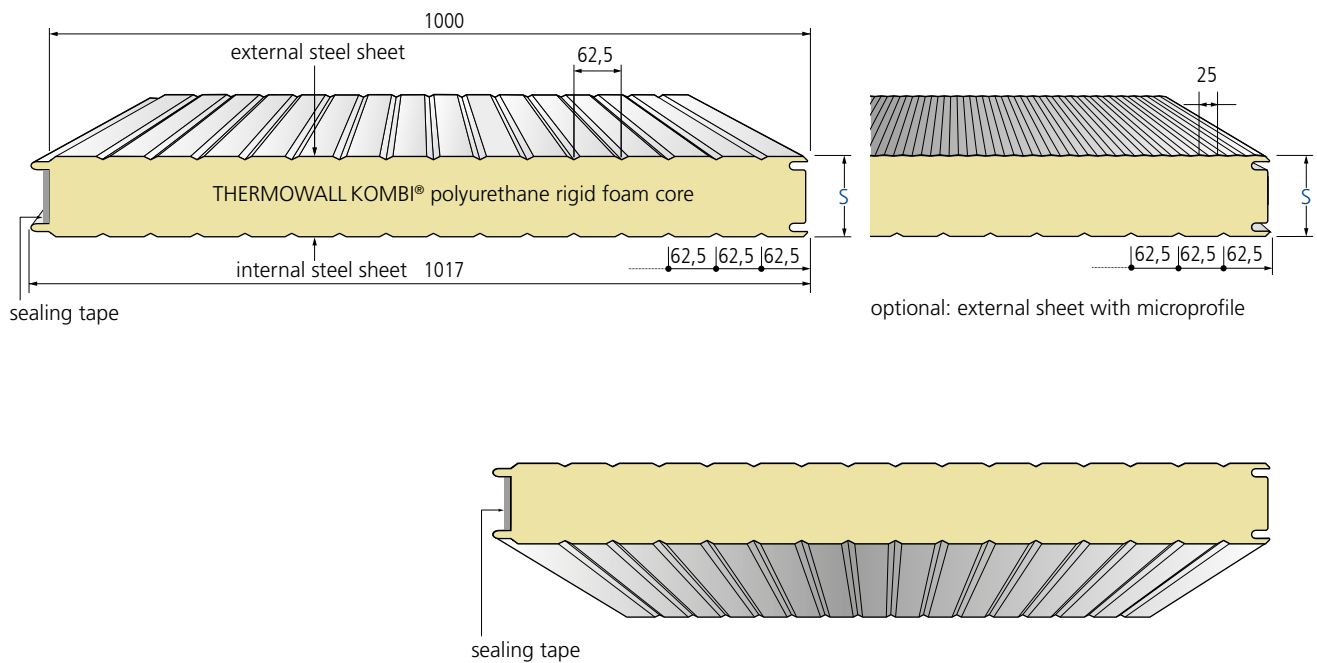

different internal profiles on request, dimensions in mm

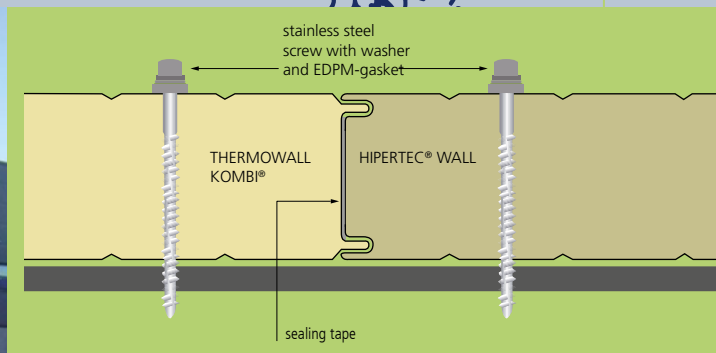

PRODUCTION AND LABELING

Production according to applicable European Building Product Regulation as per sandwich norm DIN EN 14509 label-marking in accordance with EC certificate of conformity 0769-C PR-VAS-00420

APPLICATION APPROVAL

Current approvals, certificates and general building permits at www.en.metecno.de/service.

REACTION TO FIRE

Building material classified as B-s2,d0 low flammable according to DIN EN 13501-1

THERMAL CONDUCTIVITY

$\lambda = 0.024 \text{ W / m.K}$ according to DIN 4108 and DIN EN 13165
The insulation values are regularly monitored by external bodies and may be applied without any further reduction

SOUND INSULATION

$R_w \geq 25 \text{ dB}$

STANDARD COATING

External steel sheet: 25 μm polyester

Internal steel sheet: $\approx 15 \mu\text{m}$ thin coating (DU).

For standard colours and different coating systems please refer to our colour chart

STANDARD LENGTHS

> 2.00 m to 25.00 m, greater lengths on request

CORROSION PROTECTION

According to DIN EN 10169:

External sheet: Class RC3

Internal sheet: Class RC2

According to DIN EN ISO 12944-2:

External sheet: corrosivity category C3 corresponding to average duration of protection for urban and industrial environments with moderate exposure to sulphur dioxide

Internal sheet: corrosivity category C2 for dry indoor rooms and buildings with occasional probability of minor condensation

Other coating systems are available for more sophisticated demands such as for buildings near the sea, farm buildings with high ammonia exposure or moist rooms

STANDARD STEEL SHEETS

Hot-dip galvanized steel, grade S 320 GD + Z 275 according to DIN EN 10346

TABLE OF SPANS

Please visit our website www.en.metecno.de

PACKAGING

External sheet provided with removable protective film, panel packages wrapped with banded plastic foil to protect from soiling

INTERLOCKING JOINT COMPATIBILITY WITH HIPERTEC® WALL & METFIBER® ECO WALL

type of element	core thckn. s	external steel sheet tn	internal steel sheet tn	weight kg / m ²	thermal resistance R m ² K / W	thermal conductivity (Ψ – joint effect)	
						U w/o Ψ W / m ² K	U with Ψ W / m ² K
THERMOWALL KOMBI®	60	0,60	0,45	11,5	2,46	0,398	0,413
	80	0,60	0,45	12,3	3,29	0,299	0,307
	100	0,60	0,45	13,1	4,12	0,239	0,244
	120	0,60	0,45	13,9	4,96	0,200	0,203
	150	0,60	0,45	15,1	6,21	0,160	0,162
	200*	0,60	0,45	17,1	8,29	0,120	0,121

*approval pending

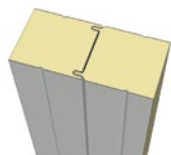

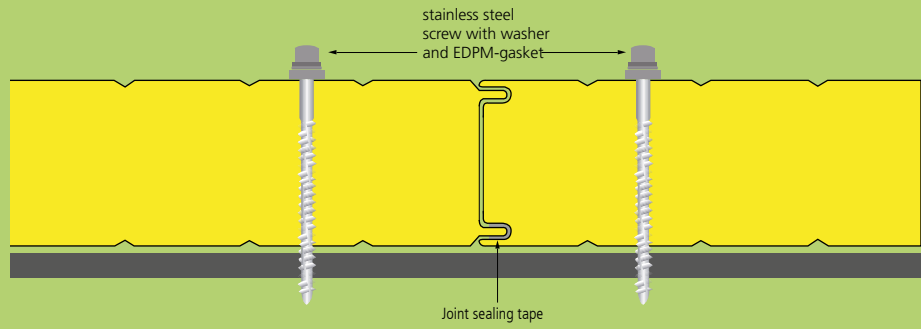

The Metfiber® Eco Wall panel with glass wool core fulfils all the requirements for non-combustible building materials. The glass wool used in this product consists of 80% recycled material, contributing significantly to the saving of natural resources and making the product an ecological building material. The deadweight of the panel is distinctly lower than that of conventional sandwich panels with rock wool insulation core, hence enabling an easier,

faster installation and cost reduction, especially for larger panels. Due to the large number of combinations with other panels from our portfolio with polyurethane or rock wool insulation core, it is possible to reach fire, acoustic and thermal requirements at once without any visual impact. More information is available in the download area www.en.metecno.de.

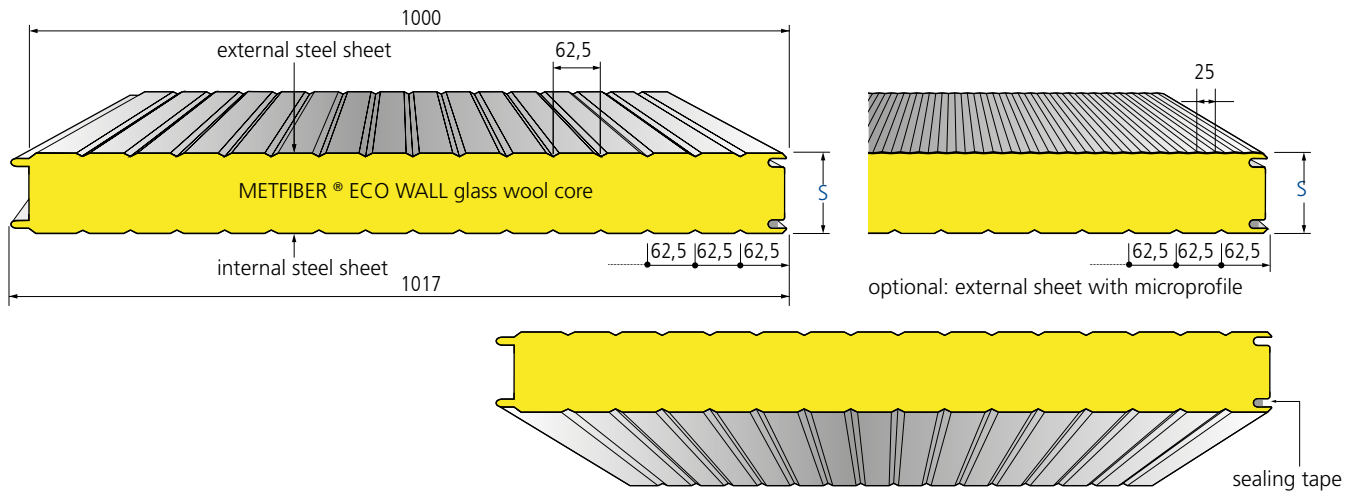

different internal profiles on request, dimensions in mm

type of element	core thickn. s	external steel sheet t _N	internal steel sheet t _N	weight	thermal resistance	thermal conductivity [Ψ - joint effect]	
						R	U w/o Ψ
	mm	mm	mm	kg / m ²	m ² K / W	W / m ² K	W / m ² K
METFIBER® ECO WALL 	100	0,50	0,50	15,14	2,54	0,384	0,390
	120	0,50	0,50	16,44	3,05	0,321	0,325
	150	0,50	0,50	18,39	3,82	0,257	0,260
	200	0,50	0,50	21,64	5,10	0,194	0,195
	240*	0,50	0,50	24,24	6,12	0,161	0,162
	* no approval / on request						



PRODUCTION AND LABELING

Production according to applicable European Building Product Regulation as per sandwich norm DIN EN 14509 label-marking in accordance with EC certificate of conformity 0769-CPR-VAS-00420

APPLICATION APPROVAL

Current approvals, certificates and general building permits at www.en.metecno.de/service.

REACTION TO FIRE

Building material classified as A2-s1,d0 non-combustible according to DIN EN 13501-1; insulation core made of glass wool

FIRE RESISTANCE*

EI 45 vertical installation (100mm core thickness)
EI 60 horizontal installation (100mm core thickness)

THERMAL CONDUCTIVITY

$\lambda = 0.039 \text{ W / m.K}$ according to DIN 4108 and DIN EN 13162 The insulation values are regularly monitored by external bodies and may be applied without any further reduction.

SOUND INSULATION

$R_w \geq 31 \text{ dB}$

STANDARD LENGTHS

> 2.00 m to 25.00 m, greater lengths on request

STANDARD COATING

External and internal steel sheet: 25 μm polyester
For standard colours and different coating systems please refer to our colour chart

CORROSION PROTECTION

According to DIN EN 10169:

External sheet: Class RC3

Internal sheet: Class RC3

According to DIN EN ISO 12944-2:

External and internal sheets: corrosivity category C3

corresponding to average duration of protection for urban and industrial environments with moderate exposure to sulphur dioxide

Other coating systems are available for more sophisticated demands such as for buildings near the sea, farm buildings with high ammonia exposure or moist rooms

STANDARD STEEL SHEETS

Hot-dip galvanized steel, grade S 320 GD + Z275 according to DIN EN 10346

TABLE OF SPANS

Please visit our website www.en.metecno.de

PACKAGING

External sheets provided with removable protective film, panel packages wrapped with banded plastic foil to protect from soiling

INTERLOCKING JOINT COMPATIBILITY WITH THERMOWALL
KOMBI® & HIPERTEC® WALL

* no approval / on request



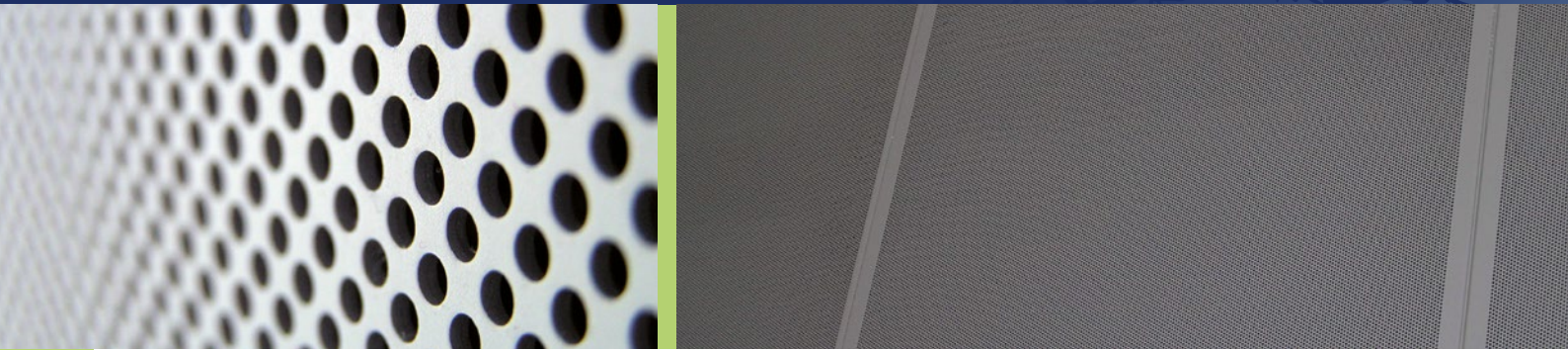

Metfiber® Eco Wall Sound is a sandwich panel with an insulation core of glass wool and steel cover sheets. It's THE solution for buildings with high requirements for noise insulation and sound absorption. The design of the perforated internal sheet improves room acoustics substantially. This system patented by Metecno applies a special fleece material as trickle protection between the internal sheet and the glass wool core. In addition to its outstanding acoustic properties, the glass wool used in this product consists

of 80% recycled material, thus contributing significantly to the saving of natural resources and making the product an ecological building material. Generally used as ceiling or partition wall Metfiber® Eco Wall Sound may also be used as external wall in specific cases, though it is generally not recommended to apply this panel in heated buildings or buildings with high moisture. More information is available in the download area www.en.metecno.de.

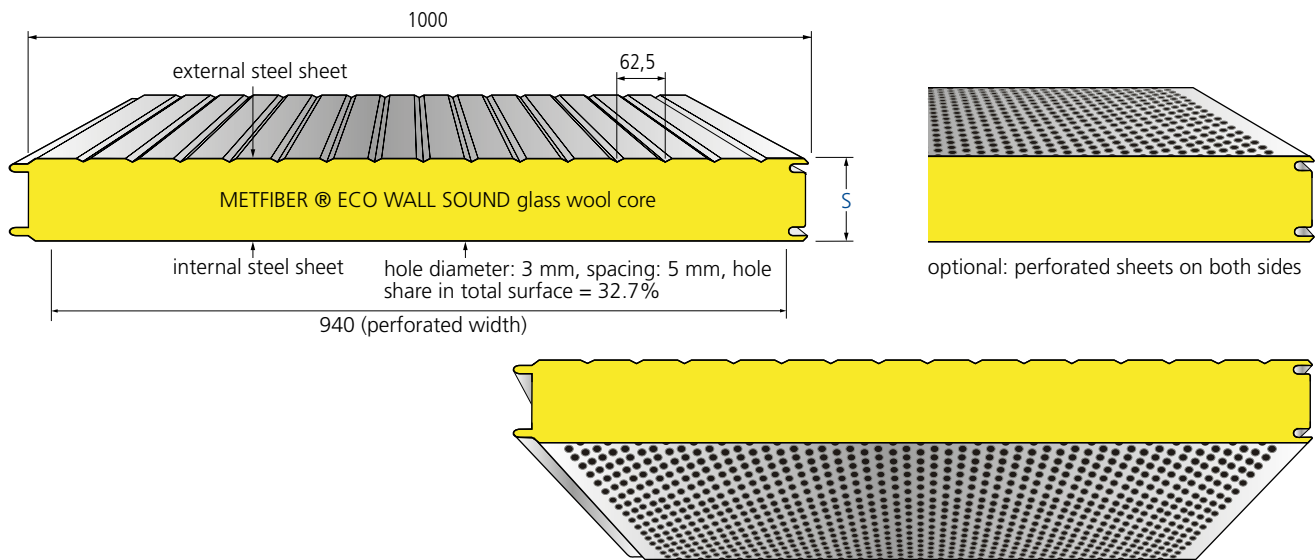

dimensions in mm

type of element	core thickn. s mm	external steel sheet t _N mm	internal steel sheet t _N mm	weight kg / m ²	thermal resistance R m ² K / W	thermal conductivity [Ψ - joint effect]	
						U w/o Ψ W / m ² K	U with Ψ W / m ² K
METFIBER® ECO WALL SOUND	100	0,60	0,60	14,7	2,54	0,37	0,38
	120	0,60	0,60	15,9	3,05	0,31	0,32
	150	0,60	0,60	17,7	3,82	0,25	0,26
	200	0,60	0,60	20,7	5,10	0,19	0,20
	240	0,60	0,60	23,1	6,12	0,16	0,16



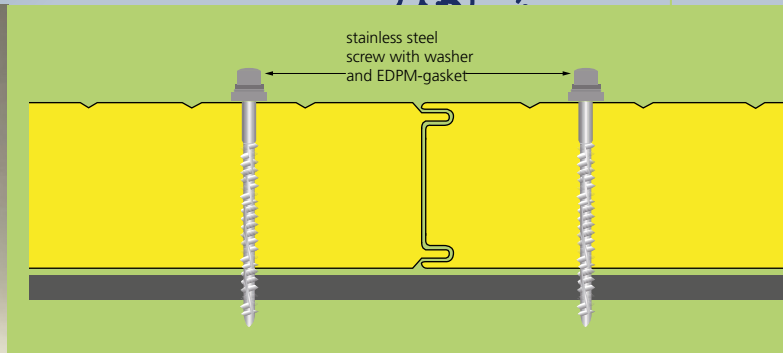

THERMAL CONDUCTIVITY

$\lambda = 0.039 \text{ W / m.K}$ according to DIN 4108 and DIN EN 13162 The insulation values are regularly monitored by external bodies and may be applied without any further reduction

STANDARD LENGTHS

> 2,00 m to 25,00 m, greater lengths on request

STANDARD COATING

External and internal steel sheet: 25 μm polyester

SOUND INSULATION

$R_w \geq 34 \text{ dB}$

SOUND INSULATION

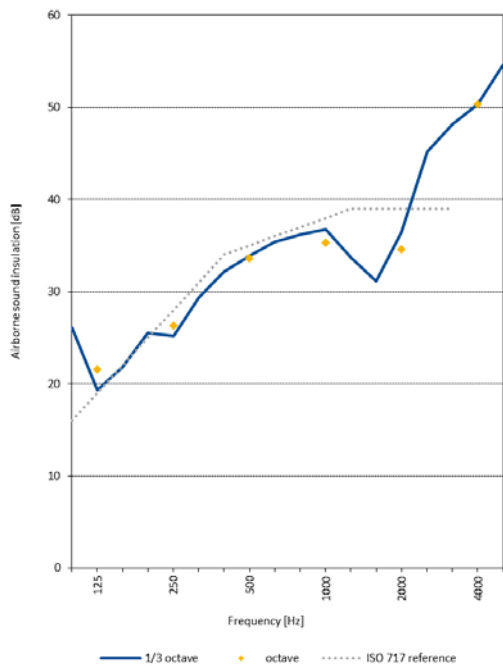

CORROSION PROTECTION

Tested according to DIN EN 10169: External sheet: Class RC3 According to DIN EN ISO 12944-2: External sheet: corrosivity category C3 corresponding to average protection duration for urban and industrial environments with moderate exposure to sulphur dioxide

PACKAGING

External and internal sheets provided with removable protective film, panel packages wrapped with banded plastic foil to protect from soiling

SOUND ABSORPTION

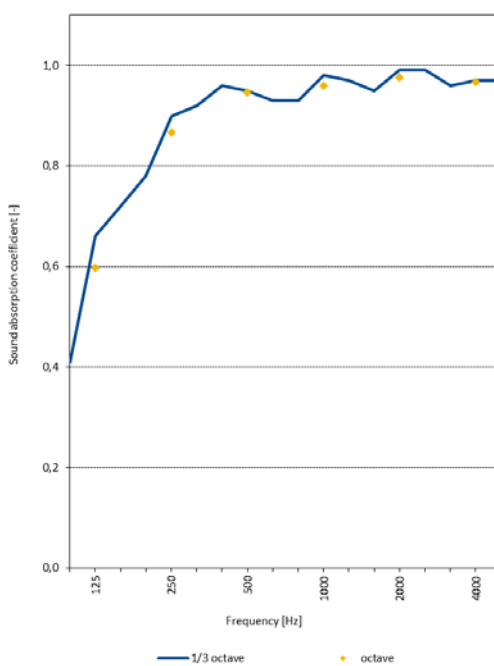

frequency Hz	thickness mm	125	250	500	1000	2000	4000
α_s	100	0,60	0,87	0,95	0,96	0,98	0,97



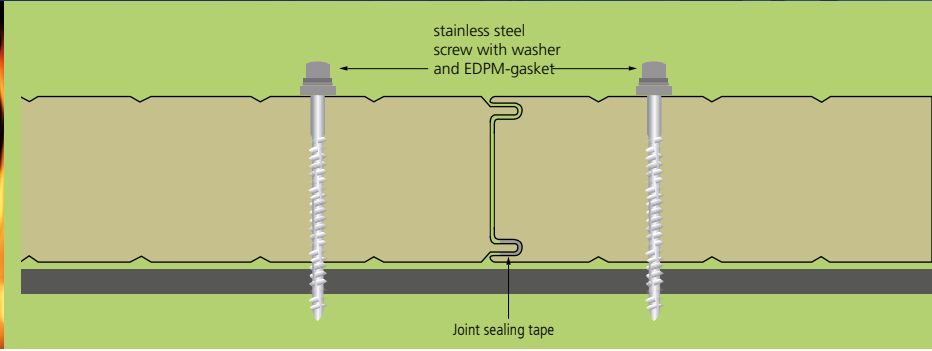

Hipertec® Wall is a sandwich panel with non-combustible insulation core made of rock wool and suits best to meet today's high requirements for fire protection and sound insulation. Depending on the core thickness the fire resistance may reach up to 120 minutes. High support widths and an easy installation both vertical and horizontal make this product very cost effective, perfectly apt for application as

separation wall or external wall. Due to the large number of combinations with other panels from our portfolio with polyurethane or glass wool insulation core, it is possible to reach fire, acoustic and thermal requirements at once without any visual impact. More information is available in the download area www.en.metecno.de.

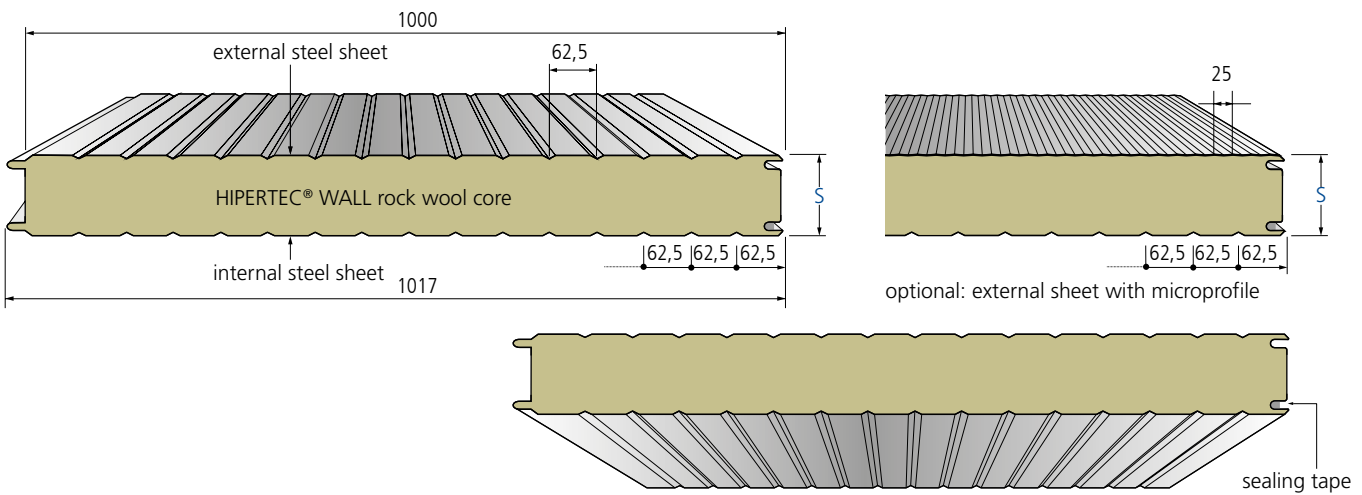

different internal profiles on request, dimensions in mm

type of element	core thickn. s mm	external steel sheet tN mm	internal steel sheet tN mm	weight kg / m ²	thermal resistance R m ² K / W	thermal conductivity [Ψ - joint effect]	
						U w/o Ψ W / m ² K	U with Ψ W / m ² K
 HIPERTEC® WALL	60	0,60	0,60	17,0	1,34	0,711	0,731
	80	0,60	0,60	19,2	1,79	0,537	0,548
	100	0,60	0,60	21,4	2,25	0,432	0,438
	120	0,60	0,60	23,6	2,70	0,361	0,365
	150	0,60	0,60	26,9	3,38	0,290	0,292
	200	0,60	0,60	32,4	4,52	0,218	0,219
	240	0,60	0,60	36,8	5,42	0,182	0,183



PRODUCTION AND LABELING

Production according to applicable European Building Product Regulation as per sandwich norm DIN EN 14509; label marking in accordance with EC certificate of conformity 0769-CPR-VAS-00420

APPLICATION APPROVAL

Current approvals, certificates and general building permits at www.en.metecno.de/service.

REACTION TO FIRE

Building material classified as A2-s1,d0 non-combustible according to DIN EN 13501-1, rock wool core A1, non-combustible, melting point > 1000°C

FIRE RESISTANCE

German building compliance certificate DIBt Application Approval Z-19.52-2096 (see table below)

THERMAL CONDUCTIVITY

$\lambda = 0.044 \text{ W / m.K}$ according to DIN 4108 and DIN EN 13162
The insulation values are regularly monitored by external bodies and may be applied without any further reduction

SOUND INSULATION

$R_w \geq 30 \text{ dB}$

SUPPORTING WIDTHS FOR ACHIEVING FIRE RESISTANCE ACCORDING GERMAN FIRE RESISTANCE APPROVAL/BRANDSCHUTZZULASSUNG Z-19.52-2096

SINGLE-SPAN INSTALLATION

panel thickn. s	vertical installation				horizontal installation			
	fire retardant EI 30	highly fire retardant EI 60	fire resistant EI 90	highly fire resistant EI 120	fire retardant EI 30	highly fire retardant EI 60	fire resistant EI 90	highly fire resistant EI 120
mm	mm	mm	mm	mm	mm	mm	mm	mm
60	4000	-	-	-	-	-	-	-
80	5000	3000**	-	-	-	-	-	-
100	5000	5000	4000	3000**	5000	5000	5000	-
120	5000	5000	5000	4000	6000	6000	5000	5000**
150	5000	5000	5000	5000	6000	6000	6000	5000**
≥200	5000	5000	5000	5000	10700	10700	9700	5000**
					panel thickn. s	vertical inst. fire retardant EI30	highly fire retardant EI60	fire resistant EI90
					mm	mm	mm	mm
MULTIPLE-SPAN INSTALLATION					mm	mm	mm	mm
maximum spans of exterior walls additionally influenced by wind load ** not for application in Germany					≥120	3500	3500	-

STANDARD COATING

External and internal steel sheet: 25 µm polyester
For standard colours and different coating systems please refer to our colour chart

STANDARD LENGTHS

> 2,00 m to 25,00 m, greater lengths on request

CORROSION PROTECTION

According to DIN EN 10169: External and internal sheet: Class RC3
According to DIN EN ISO 12944-2: External and internal sheet: corrosivity category C3 corresponding to average duration of protection for urban and industrial environments with moderate exposure to sulphur dioxide. Other coating systems are available for more sophisticated demands such as for buildings near the sea, farm buildings with high ammonia exposure or moist rooms

STANDARD STEEL SHEETS

Hot-dip galvanized steel, grade S 320 GD + Z 275 according to DIN EN 10346

TABLE OF SPANS

Please visit our website www.en.metecno.de

PACKAGING

External sheets provided with removable protective film, panel packages wrapped with banded plastic foil to protect from soiling
INTERLOCKING JOINT COMPATIBILITY WITH METFIBER® ECO WALL & THERMOWALL KOMBI®



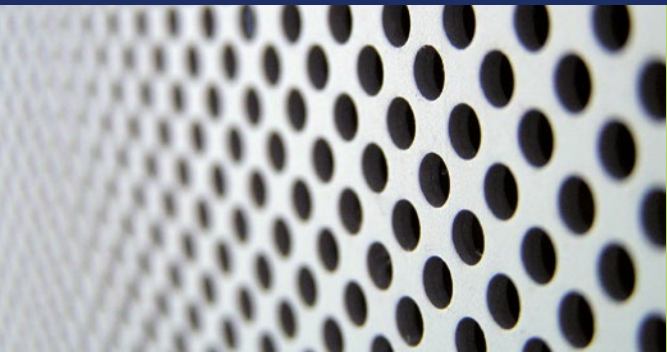

Hipertec® Wall Sound is a sandwich panel with an insulation core of mineral wool and steel cover sheets, the internal sheet being perforated. This panel is perfectly apt for buildings with high requirements for noise insulation and sound absorption. The design of the internal sheet improves room acoustics substantially. This system patented by Metecno applies a special fleece as trickle pro-

tection between the internal sheet and the rock wool core. Generally used as ceiling or partition wall, Hipertec® Wall Sound may also be used as external wall in specific cases, though it is generally not recommended to apply this panel in heated buildings or buildings with high moisture. More information is available in the download area www.en.metecno.de.

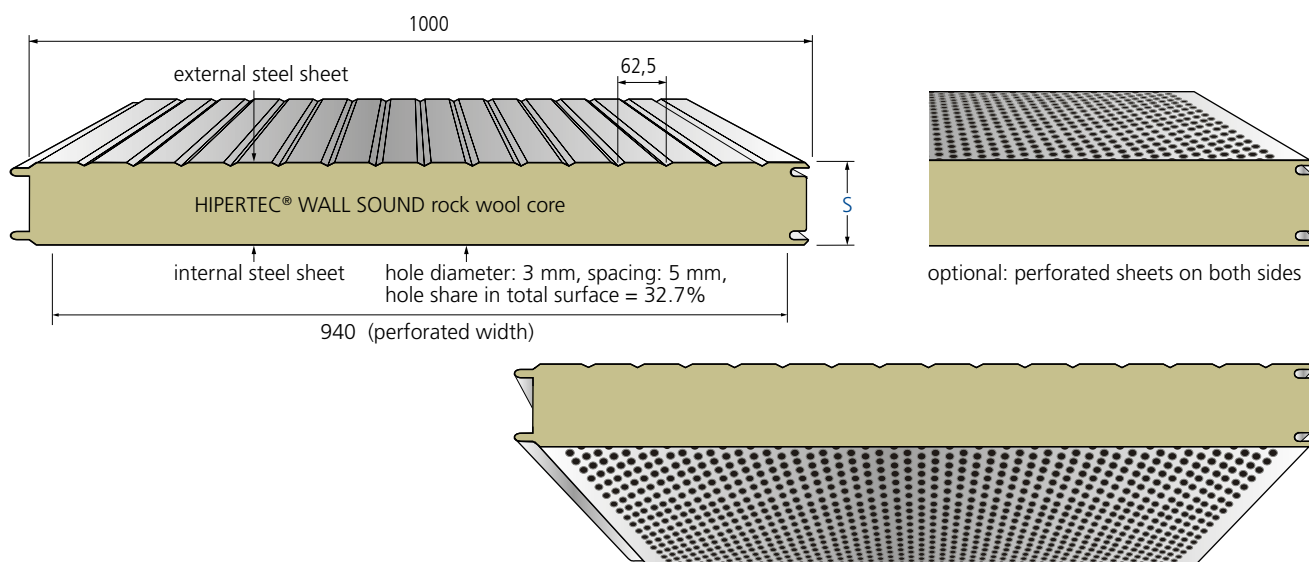

dimensions in mm

type of element	core thickn. s mm	external steel sheet tN mm	internal steel sheet tN mm	weight kg / m ²	thermal resistance R m ² K / W	thermal conductivity [Ψ - joint effect]	
						U w/o Ψ W / m ² K	U with Ψ W / m ² K
HIPERTEC® WALL SOUND	60	0,60	0,60	15,3	1,34	0,711	0,731
	80	0,60	0,60	17,5	1,79	0,537	0,548
	100	0,60	0,60	19,7	2,25	0,432	0,438
	120	0,60	0,60	21,9	2,70	0,361	0,365
	150	0,60	0,60	25,2	3,38	0,290	0,292
	200	0,60	0,60	30,7	4,52	0,218	0,219
	240	0,60	0,60	35,1	5,42	0,182	0,183

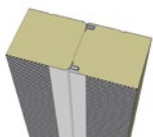

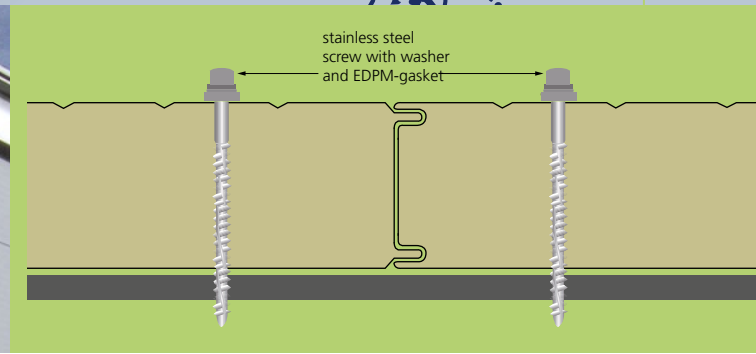

THERMAL CONDUCTIVITY

$\lambda = 0.044 \text{ W / m.K}$ according to DIN 4108 and DIN EN 13162
 The insulation values are regularly monitored by external bodies and may be applied without any further reduction

STANDARD LENGTHS

> 2,00 m to 25,00 m, greater lengths on request

STANDARD COATING

External and internal steel sheet: 25 μm polyester

SOUND ABSORPTION

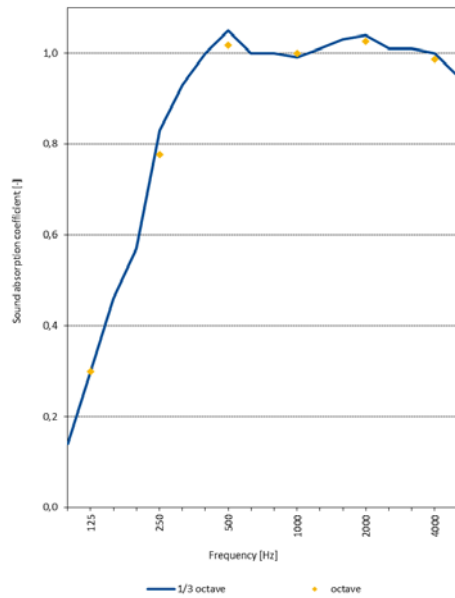

CORROSION PROTECTION

Tested according to DIN EN 10169:
 External sheet: Class RC3
 According to DIN EN ISO 12944-2:
 External sheet: corrosivity category C3 corresponding to average protection duration for urban and industrial environments with moderate exposure to sulphur dioxide

PACKAGING

External and internal sheets provided with removable protective film, panel packages wrapped with banded plastic foil to protect from soiling

SOUND INSULATION

Rated sound insulation $R_w \geq 35 \text{ dB}$

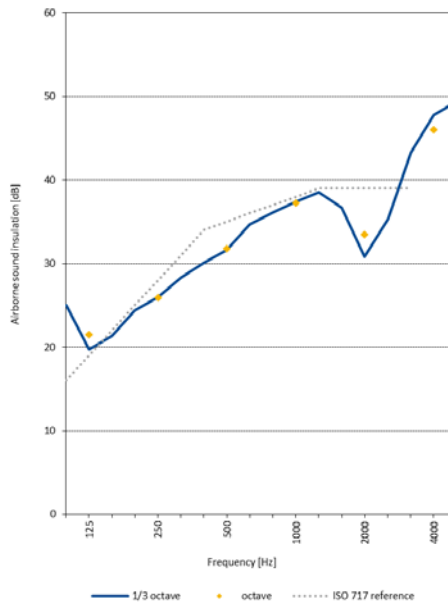

SUPPORTING WIDTHS FOR ACHIEVING FIRE TESTING

SINGLE-SPAN INSTALLATION vertical installation

core thickn. s		EI 30	EI 45	EI 60
120	partition	7,50 m*	6,00 m*	4,00 m*
120	outer wall i→o	7,50 m*	-	4,00 m*

maximum spans of exterior walls additionally influenced by wind load

* not for application in Germany

frequency Hz | **thickn. mm** | **125** | **250** | **500** | **1000** | **2000** | **4000**

α_s	60	0,30	0,78	1,02	1,00	1,03	0,99
------------	----	------	------	------	------	------	------





This sandwich panel with sinus corrugated external sheet and hidden fixing is a great esthetical option for modern facades by giving them a lively touch with its original wave design. The highly heat insulating CFC and HCFC free polyurethane rigid foam core suits best for today's requirements for thermal insulation and moisture protection. A non-displaceable sealing strip foamed into the longitudinal joint procures resistance to driving rain and wind. Together

with the organic coating of the steel sheets this ensures efficient protection against all kinds of weather. For advanced application additional coating systems are available. More information is available in the download area www.en.metecno.de.

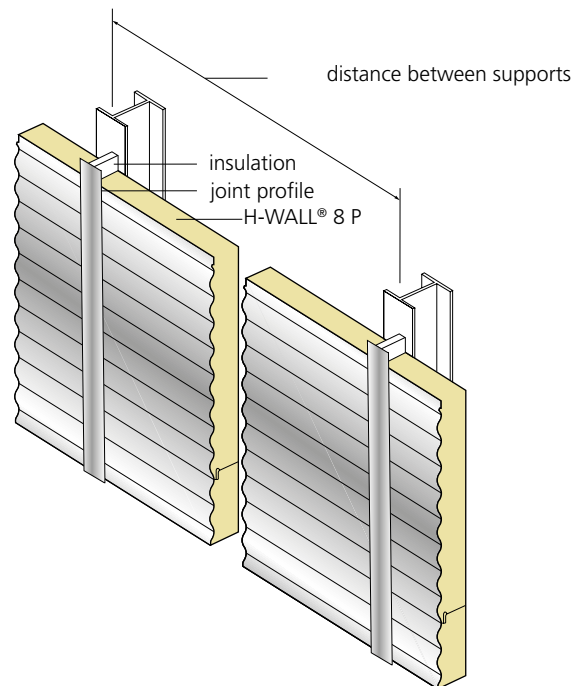
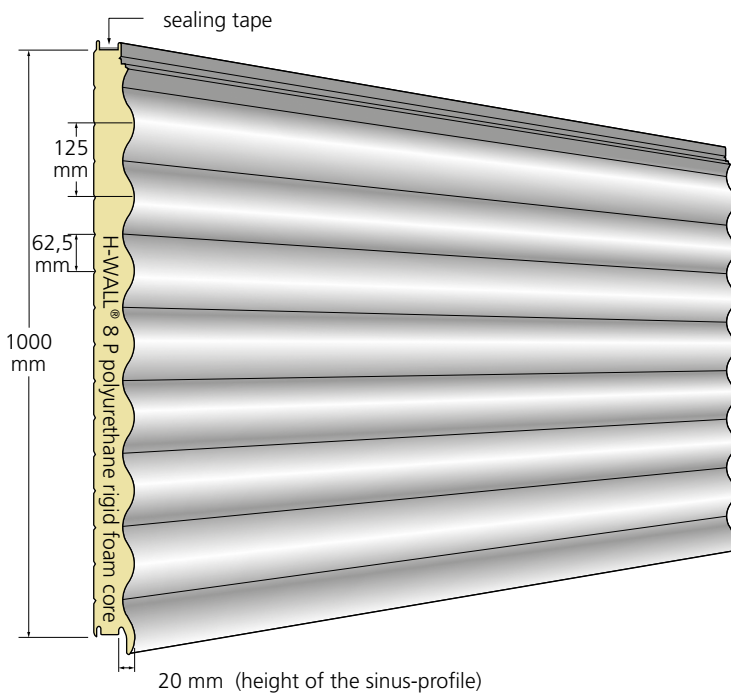

different internal profiles on request, dimensions in mm

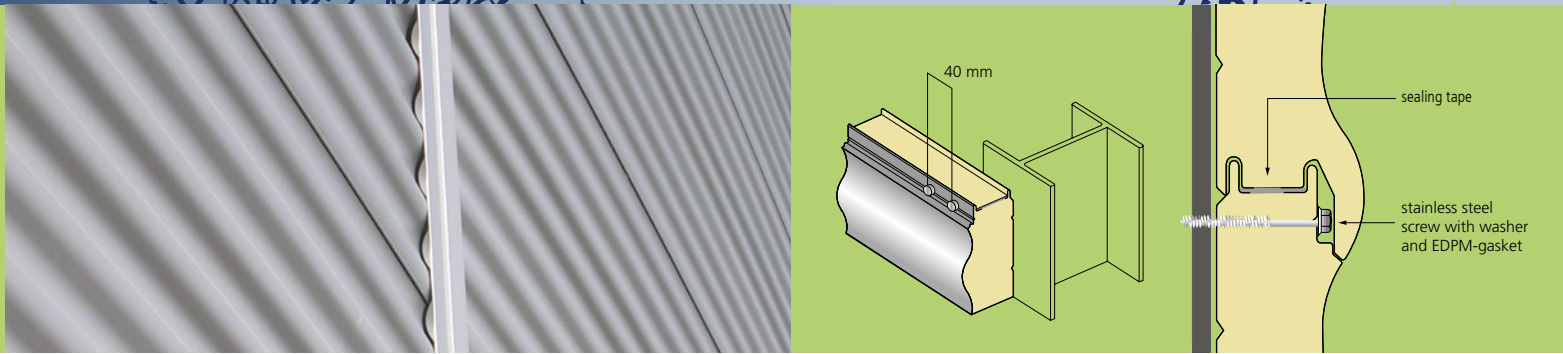

PRODUCTION AND LABELING

Production according to applicable European Building Product Regulation as per sandwich norm DIN EN 14509 label-marking in accordance with EC certificate of conformity 0769-C PR-VAS-00420

APPLICATION APPROVAL

Current approvals, certificates and general building permits at www.en.metecno.de/service.

REACTION TO FIRE

Building material classified as B-s2,d0 low flammable according to DIN EN 13501-1

THERMAL CONDUCTIVITY

$\lambda = 0.024 \text{ W / m.K}$ according to DIN 4108 and DIN EN 13165
The insulation values are regularly monitored by external bodies and may be applied without any further reduction

SOUND INSULATION

$R_w \geq 25 \text{ dB}$

STANDARD COATING

External steel sheet: 25 μm polyester;
Internal steel sheet: $\approx 15 \mu\text{m}$ thin coating (DU); For standard colours and different coating systems please refer to our colour chart

STANDARD LENGTHS

> 2,00 m to 25,00 m, greater lengths on request

CORROSION PROTECTION

According to DIN EN 10169:
External sheet: Class RC3
Internal sheet: Class RC2

According to DIN EN ISO 12944-2:
External sheet: corrosivity category C3 corresponding to average duration of protection for urban and industrial environments with moderate exposure to sulphur dioxide
Internal sheet: corrosivity category C2 for dry indoor rooms and buildings with occasional probability of minor condensation
Other coating systems are available for more sophisticated demands such as for buildings near the sea, farm buildings with high ammonia exposure or moist rooms

STANDARD STEEL SHEETS

Hot-dip galvanized steel, grade S 320 GD+ Z 275 according to DIN EN 10346

TABLE OF SPANS

Please visit our website www.en.metecno.de

PACKAGING

External sheet provided with removable protective film, panel packages wrapped with banded plastic foil to protect from soiling

type of element	core thickn. s mm	total thickn. D mm	external steel sheet tN mm	internal steel sheet tN mm	weight kg / m ²	thermal resistance R m ² K / W	thermal conductivity [Ψ – joint effect]	
							U w/o Ψ W / m ² K	U with Ψ W / m ² K
H-WALL® 8 P 	50	70	0,60	0,45	12,2	2,04	0,408	0,438
	80	100	0,60	0,45	13,4	3,29	0,270	0,281
	100	120	0,60	0,45	14,2	4,12	0,221	0,227





Discover our new design corners made of sandwich panels for the execution of your individual architectural ideas...

- ... with a maximum panel length of 8,000 mm!*
- ... with a minimum side length of 200 mm!*
- ... as horizontal or vertical corners!
- ... as external corners as well as internal corners!
- ... with core thicknesses from 30 mm up to 200 mm!*
- ... with an insulation core made of rock -/ glass wool or PIR foam!



In cooperation with On Spot Manufaktur Leipzig.



* different dimensions on request

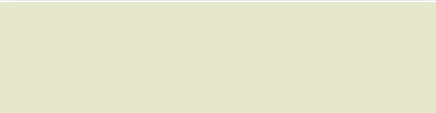
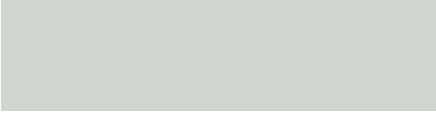
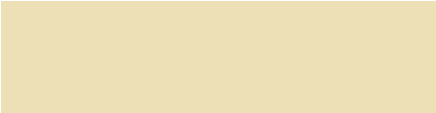

METCOLOR STANDARD COLOUR SHADES | POLYESTER

COLOR GROUP 1

MC 9002 grey white

MC 7035 light grey

MC 1015 light ivory

MC 9010 pure white









COLOR GROUP 2

MC 6011 reseda green

MC 9006 white aluminum

MC 9007 grey aluminum

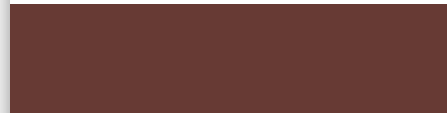
aluzinc

MC 7037 dusty grey

COLOR GROUP 3*

MC 6020 chrome green

MC 6005 moss green

MC 7016 anthracite grey

MC 5010 gentian blue

MC 8004 copper brown

MC 8011 nut brown

MC 8012 red brown

MC 3000 flame red

MC 3009 oxide red

Metecno colours are oriented on RAL colours. Variations in colour may occur due to the printing process. Coloured steel samples are available for precise matching. It is recommended to check availability of colours and coating systems with sales department prior to order. Design of inner surfaces may vary with the product itself (see product data sheets).

* minimum core thickness 40mm

METCOLOR COATING SYSTEMS

STANDARD COATING FOR EXTERNAL APPLICATION 25 µm POLYESTER

Corrosivity category RC3 in accordance with DIN EN 10169:2022-06 UV resistance category RUV2 in accordance with DIN EN 10169:2022-06

Temperature exposure -20° to 80°C

The well-proven polyester-coating is a modern and cost-effective coating system, adapting well to different colour finishes. Polyester-coatings show good corrosion- and weather resistance under normal conditions for industrial application within the Central European region, which makes it the most commonly used coating system.

STANDARD COATING FOR INTERNAL APPLICATION 15 µm DU-POLYESTER

Corrosivity category RC2 in accordance with DIN EN 10169:2022-06 Temperature exposure -20° to 80°C

The polyester-thin-coating (standard colour shade similar to MC 9002) is suitable for conventional industrial buildings for indoor application in rooms with normal room climate and normal relative humidity. The colour shade may not be uniform due to the coating thickness.

25 µm OR 35 µm PVDF (POLYVINYLIDENFLUORIDE)

Corrosivity category RC3 (25 µm) or RC4 (35 µm) in accordance with DIN EN 10169:2022-06

UV resistance category RUV4 in accordance with DIN EN 10169:2022-06

Temperature exposure -20° to 110°C

This coating shows optimal resistance against UV-radiation and weather and has good ductility. It is suited particularly well for high requirements on the colour finish and has been found to be excellent in regions with difficult climatic conditions (e.g., 5-15 km from the sea).

50 µm POLYAMIDE MODIFIED POLYURETHANE (PUR-PA)

Corrosivity category RC5 in accordance with DIN EN 10169:2022-06 UV resistance category RUV4 in accordance with DIN EN 10169:2022-06

Temperature exposure -20° to 80°C

By using polyamide this coating system reaches a high surface hardness. Its visibly grained structure is particularly resistant to abrasion and ensures efficient protection against mechanical damage. It is also widely resistant to strain by animals such as poultry, making it ideally apt for agricultural application. The flexibility and excellent resistance to UV-radiation make this coating also well suitable for outdoor installation.

TYPICAL COATING SYSTEM

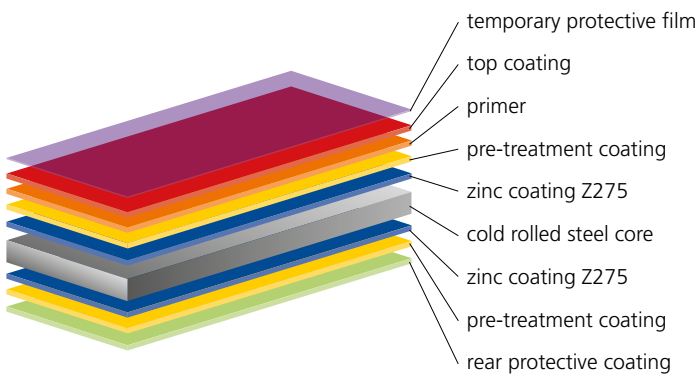

FLASHINGS

made of galvanized, coated steel
material thickness 0,75 mm; maximum length up to 6.000 mm

side A: 25 µm polyester coating with protective film

side B: RSL protective back coating

available in colours matching the panels cover sheets

production possible on the basis of profile drawings sent by customer or standard drawings from our flashings catalogue
special designs on request

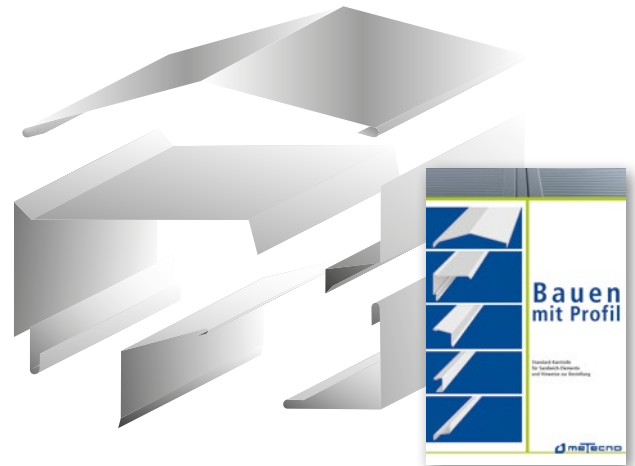

DESIGN DETAILS

Our planning folder contains detailed application solutions in PDF-and DWG-format (available at www.en.metecno.de). It also contains text templates for quick preparation of tenders with our sandwich elements and flashings. The BIM objects for our sandwich panel product line are available for download at www.bimobjects.com.

G4® ROOF PANEL eaves detail

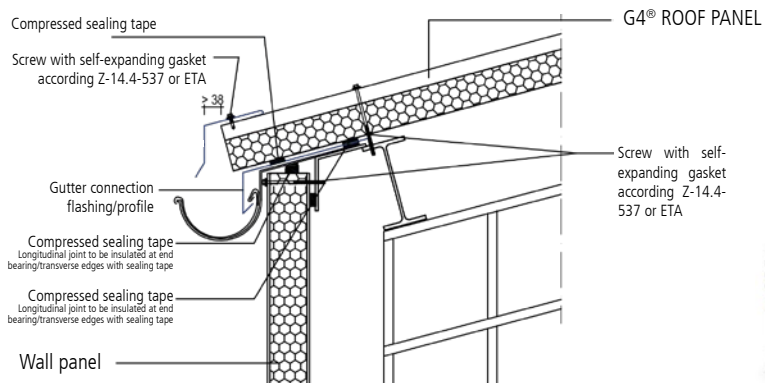

source: ATeO-Service

PRESSING TOOL FOR SANDWICH WALL PANELS

In order to comply with the joint flow rate coefficient of $\leq 0,1\text{m}^3/(\text{mh}/\text{daPa})$ required by DIN 18542, we recommend the use of pressing tools for the installation of sandwich wall panels in order to ensure the necessary compression of the sealing tapes in the longitudinal joint.

Item No. MET-ADV-WO1



RIDGED COVER FLASHING FOR G4® AND HIPERTEC® ROOF

Item No. ZB-A38, Z = 120 mm / L = 1000 mm



RIDGED COVER FLASHING FOR H-WALL® 8 P

Item No. ZB-H8, Z = 50 mm / L = 1000 mm



FILLER BLOCKS FOR G4® AND HIPERTEC® ROOF

Item No. DB-A38-01, W = 30 mm / L = 1000 mm
 Item No. DB-A38-02 (self-adhesive)



FILLER BLOCKS FOR H-WALL® 8 P

Item No. DB-H8, W = 30 mm / L = 1000 mm



SELF-ADHESIVE COMPRESSION TAPES

Item No. SDB-E, size 10 / 2-4 mm (10 / 2-3 mm), 22 m/roll
 Item No. SDB-E, size 14 / 2-4 mm (15 / 2-3 mm), 22 m/roll
 Item No. SDB-E, size 14 / 2-6 mm (15 / 3-6 mm), 18 m/roll

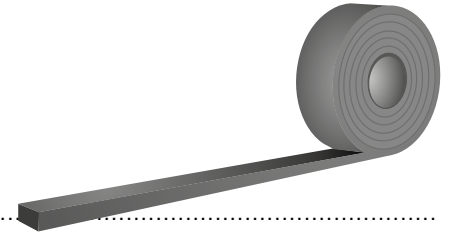

SADDLE CAPS

Item No. KL colour code -01, made of aluminium with vulcanized sealing

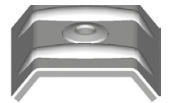

Z-LOAD DISTRIBUTION PLATE (Z-SADDLE CAP) FOR SUPERWALL® ML, SUPERWALL® HF, METFIBER ECO HF AND H-WALL® 8 P

for hidden fixing with higher tensile forces
 Item No. KL-V2A-04

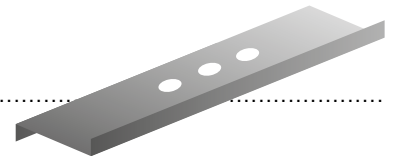

CORRUGATED PROFILE G4 (38/333/1000)

can be combined with sandwich panel
 G4® and Hipertec® ROOF
 e.g. canopies



Side A: 25 µm Polyester coating with protective film / Side B: RSL-protective lacquer
 lengths: 1.500 mm to 15.000 mm (other lengths on request) / sheet thicknesses: 0,50 mm, 0,60 mm, 0,75 mm

CORRUGATED PROFILE H8 (20/125/875)

Same profile as panel H-Wall® 8 P
 e.g. for cladding of solid walls

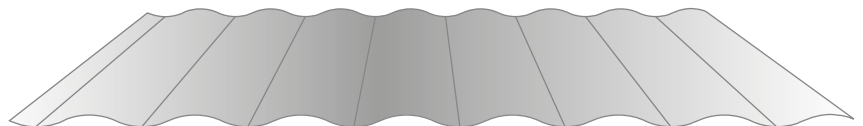

Side A: 25 µm Polyester coating with protective film / Side B: RSL-protective lacquer
 lengths: 2.000 mm to 7.500 mm (other lengths on request) / sheet thicknesses: 0,75 mm

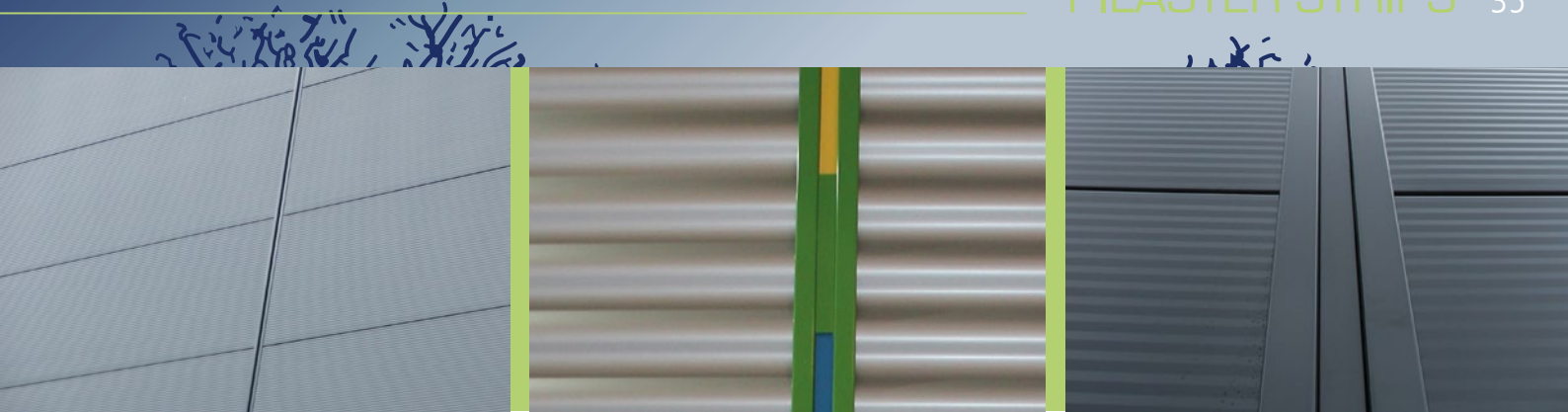

Our pilaster strips are easy to install and available in two versions, each with two different cover strips. These aluminium profiles are made of EN AW-6060T66 EN 755-9-material with available lengths up to 6.000 mm. The pilaster strips are powder coated and available in any RAL colour finish. The minimum purchase quantity: 84 lm.

Your benefits at a glance:

- + light-weight construction
- + no displacement after installation due to tight fit
- + rounded edges for uniform joint appearance
- + installation aid to prevent damage

Pilaster strip 110

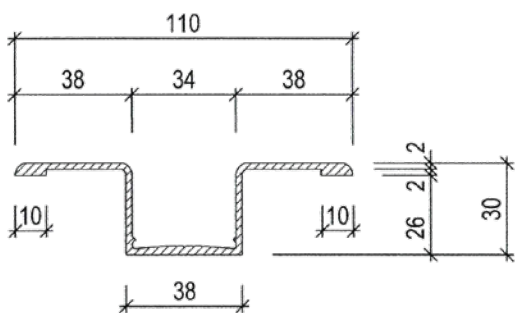

cover strip, large

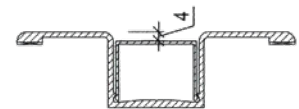
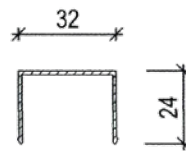

cover strip, small

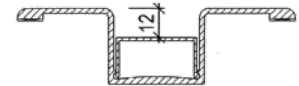
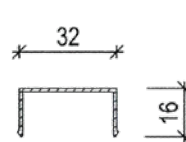

dimensions in mm

Pilaster strip 160*

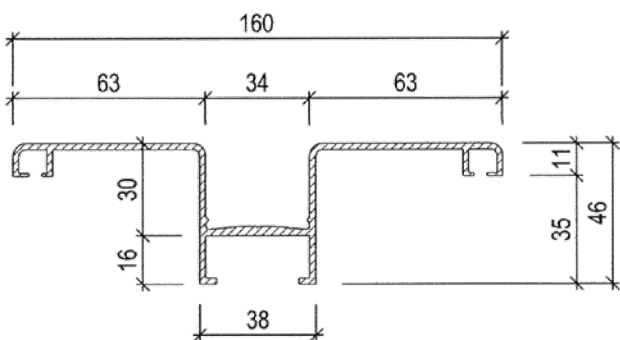

cover strip, large

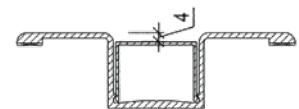
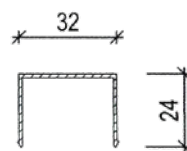

cover strip, small

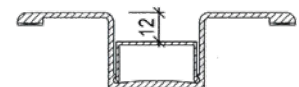
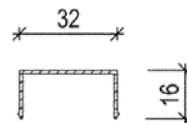

dimensions in mm

*EPDM-seal mandatory
(individual delivery not possible/ 50 m per roll)





GERMANY

HELMUT HAGEN

NORTH

phone: +49 364 5456811
mobile: +49 163 8203120
helmut.hagen@metecno.de

FRANK HERMANN

MIDDLE WEST

phone: +49 201 74707596
mobile: +49 151 18255223
frank.hermanns@metecno.de

JUTTA KREUTZ

WEST

phone: +49 2747 9136350
mobile: +49 151 23531411
jutta.kreutz@metecno.de

MARKUS BAYHA

SOUTH WEST

phone: +49 7151 2060980
mobile: +49 163 8203115
markus.bayha@metecno.de

RONALD FÖRSTER

NORTH-EAST

phone: +49 381 81727535
mobile: +49 176 11382009
ronald.foerster@metecno.de

RÜDIGER ARZT

MIDDLE

phone: +49 5086 2900663
mobile: +49 176 10601841
ruediger.arzt@metecno.de

STEVEN STELLISCH

EAST

phone: +49 36454 56 197
mobile: +49 171 7663706
steven.stellisch@metecno.de

DANIEL BENKEK

SOUTH EAST

mobile: +49 163 8203118
daniel.benkek@metecno.de

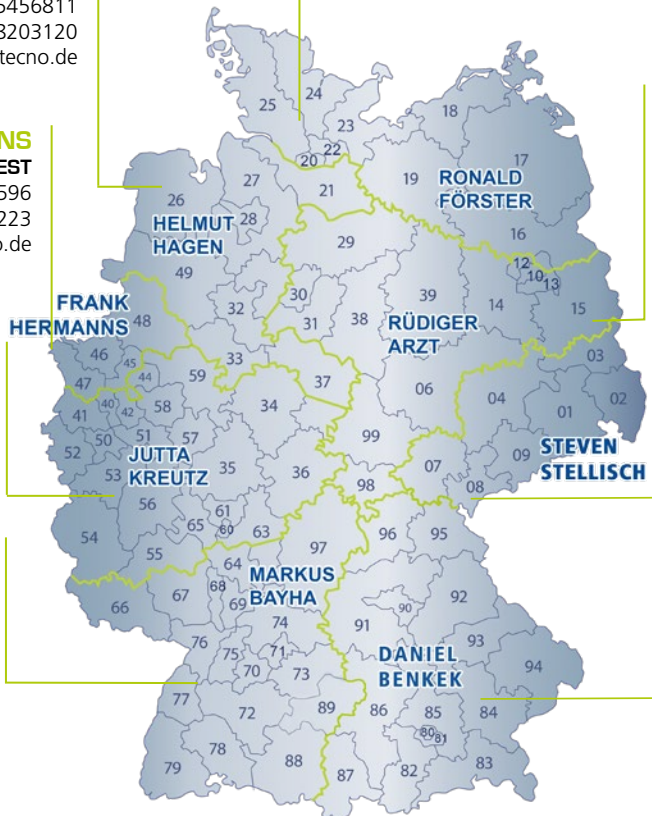

AUSTRIA

MAXIMILIAN HUBER

AUSTRIA WEST

mobile: +43 664 184 54 50
m.huber@metecno.at

PETER HAWLE

APPLICATION TECHNICAL ADVICE

mobile: +43 6648826 7237
peter.hawle@metecno.de

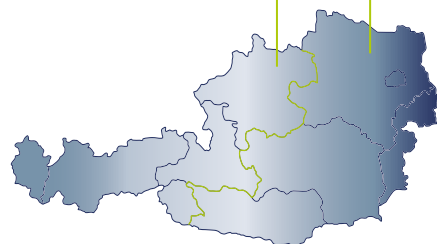

CZECH REPUBLIC & SLOVAKIA

GEORG DUMPENNIK

phone: +43 158526 1815
g.dumpelnic@metecno.at

METEC-NO SOUND - YOUR SPECIALISTS FOR ACOUSTICS

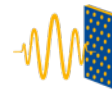

metecno

SOUND

MARKUS BAYHA

D-A-CH

phone: +49 7151 20609 80
mobile: +49 163 8203115
markus.bayha@metecno.de
akustik@metecno.de

FRANCOIS CORTEN

FRANCE

phone: +32 4387 8825
mobile: +32 4734 71835
francois.corten@metecno.de
acoustics@metecno.de

ANDREW KOSTER

EXPORT

phone: +31 6837 06436
andrew.koster@metecno.de
sound@metecno.de

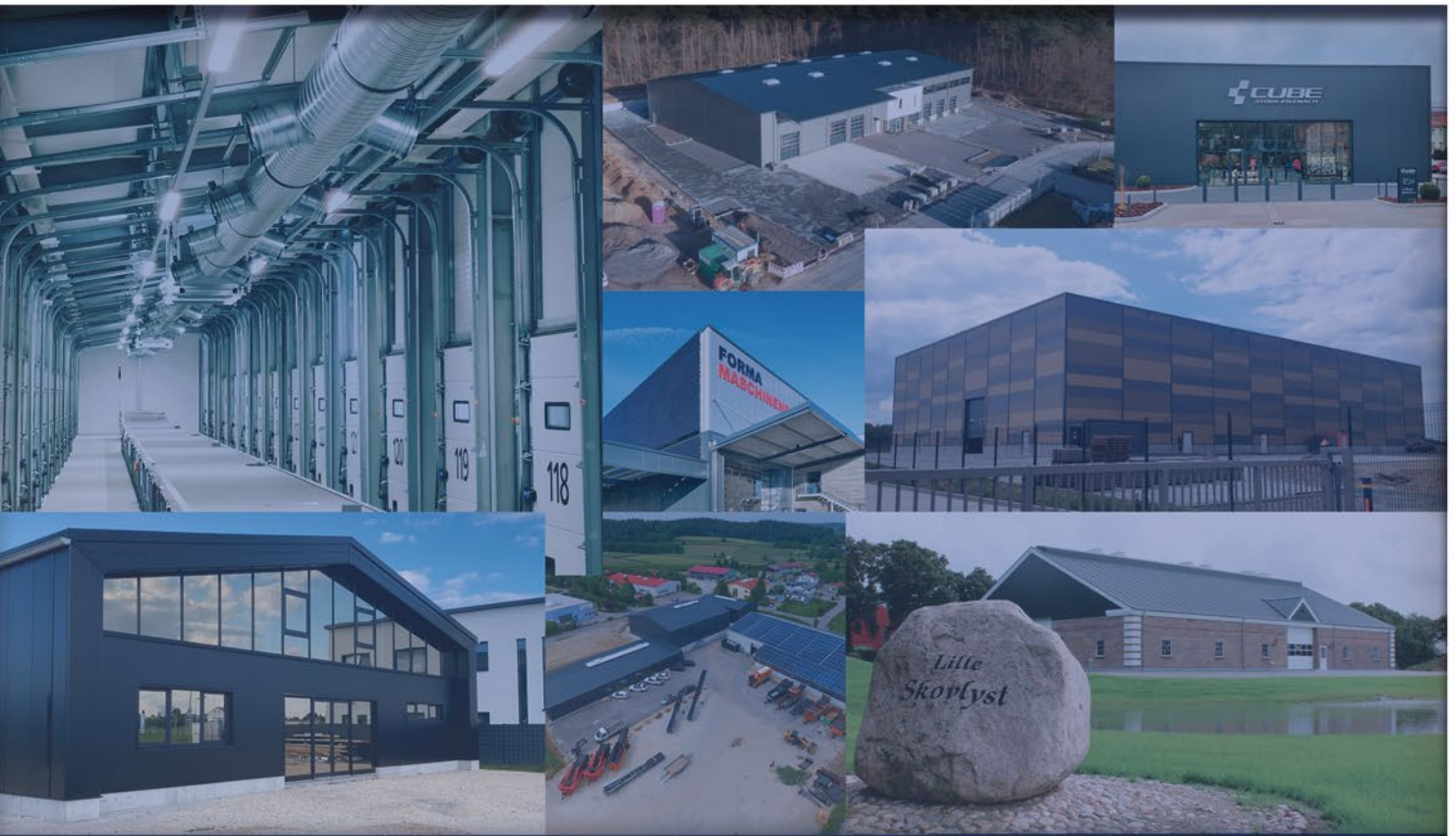

CE
 ASSOCIATED MEMBER OF
IFBS
 Member of
 European Association for
Panels and Profiles

 CERTIFIED ACCORDING TO
 ISO 9001:2015

Official partner of:









GERMANY

Metecno Bausysteme GmbH
Am Amselberg 1
D-99444 Blankenhain
phone +49 36454 56 0
fax +49 36454 56 100
e-mail vertrieb@metecno.de
www.metecno.de

AUSTRIA

Metecno Bausysteme GmbH
Margaretenstr. 72
A-1050 Vienna
phone +43 1 58 52 618
fax +43 1 58 52 618 18
e-mail office@metecno.at
www.metecno.at

BELGIUM

Metecno Bausysteme GmbH
phone +32 4 387 88 25
e-mail benelux@metecno.de
www.metecno.de

Applicable general terms of sales available on request
Metecno reserves the right to make necessary changes and improvements to the products without prior notice
Metecno is not responsible for errors, including typos.

WWW.METECNO.DE

ARGENTINA

Oficina Argentina
Calle Humboldt N°1510
3er. Piso (1414)
Buenos Aires
phone (54-11) 4777-7231
e-mail info@metecnoargentina.com
www.metecnoargentina.com

AUSTRALIA

Metecno Pty Ltd
111 Ingram Rd, Acacia Ridge
Queensland, 4110
phone +61 (07) 3323 8500
www.bondor.com.au

BULGARIA

Metecno Bulgaria AD
Grivishko shosse 1
5800 Pleven
phone +359 64 882 900
fax +359 64 841 180
e-mail info@metecno.bg
www.metecno.bg

CHILE

Metecno de Chile S.A.
AV. Nueva Industria 200
Comuna de Quilicura,
Santiago de Chile
phone +56 2 438 7590
fax +56 2 438 7500 / 90
e-mail info@metecno.cl
www.metecno.cl

CHINA

**Zhejiang Metecno
New Buidling Panels, CO., LTD.**
N° 66, Jianshe 3rd Road, Xiaoshan
Economic & Technical Development
Zone, Hangzhou City, Zhejiang
Province, PR China
phone +86 571 826 08802
fax +86 571 826 08808
e-mail gmooffice@metecno-zj.cn
www.metecno-zj.cn

GREECE

Metecno Hellas
Π. ΣΕΡ. ΤΣΑΚΜΑΝΗ 3-5
572 00 ΛΑΓΚΑΔΑΣ - ΘΕΣΣΑΛΟΝΙΚΗ
ΤΗΛ./FAX: 23940 23738
KIN.: 6981 241281
e-mail info@metecno.gr
www.metecno.gr

INDIA

Metecno India Pvt Ltd.
138/30, 2ND FLOOR FLORIDA TOWERS,
NELSON MANICKAM ROAD,
CHENNAI - 29.
phone +91 44 - 45608800
fax +91 44 43553351
e-mail enquiry@metecno.in
www.metecno.in

INDONESIA

PT Bondor Indonesia
Kawasan Industri Sentul
Jalan Olympic Raya Kav. A2
Sentul - Bogor 16180
phone +62-21-8756001
fax +62-21-8756017
e-mail sales@bondor.co.id
www.bondor.co.id

ITALY

Metecno Italia srl
Zona Industriale Cimafava
29013 Carpaneto, Piacentino
phone +39 0523 853811
fax +39 0523 859728
www.metecno.com

Metecno Italia srl
Via Nazario Sauro
33090 Fraz. Toppo, Travesio
phone +39 0427 591311
fax +39 0427 90168
www.metecno.com

COLOMBIA

Metecno de Colombia S.A.
Parque Industrial El Paraíso Manzana C Lote 16
Santander de Quilichao - Cauca
phone +57 2 8295290
fax +57 2 8295292
e-mail ventas@metecnocolombia.com
www.metecnocolombia.com

MEXICO

Metecno Mexico S. A. de C. V.
Av. Mesa de Leon No.116,
C.P. 76220 S.Rosa Jauregui, Queretaro
phone (52-442) 229-5300
e-mail ventas@metecnomexico.com
www.metecnomexico.com

PERU

Oficina Peru
Av. Andres Aramburu No 855
Con Calle Las golondrinas No 393
Esquina DP 302
phone (511) 421-3893
e-mail info@metecnoperu.com
www.metecnoperu.com

ROMANIA

Metecno Trading Romania SRL
Str. Mihail Kogalniceanu nr. 17
Bloc C4, Etaj 1, Apartament 1
500090 Brasov ROMANIA
phone +40 268 406 249
fax +40 268 406 248
e-mail office@metecno.ro
www.metecno.ro

SPAIN

Metecno España S.A.
Poligono Industrial de Bayas
Parcelas 107-110
09200 Miranda de Ebro, Burgos
phone +34 947 330690
fax +34 947 330678
e-mail info@metecnoes.com

LANKA

Metecno Lanka (PVT) LTD
No. 185, Korathota, Kaduwela,
Sri Lanka
phone +94 115 795100
fax +94 115 443322
e-mail info@metecnolanka.lk
info@metroof.lk
www.metecnolanka.com

THAILAND

Metecno Pannelli (Thailand)
25 Moo 9, Soi Watmahawong
Poochaosamingprai, Samrong-klang
Samutprakarn 10130
phone +66 2 755-9265
fax +66 2 754-3482
e-mail wanchai@metecno.co.th

VIETNAM

Metecno Vietnam LTD.
Sales office
Room No. F34,
40 Ba Huyen Thanh Quan Street,
District 3, Ho Chi Minh City,
S.R. Vietnam
phone +84 8 930 0962, 930 0973
fax +84 8 930 0991
e-mail sudarshan.bt@metecno.com.vn
diep.ta@metecno.com.vn

Metecno Vietnam LTD.

Lot No. 13, Road No. 16A
Bien Hoa Industrial Zone 2,
Bien Hoa City
Dong Nai Province
S.R.Vietnam
phone +84 61 3833 640 - 641
fax +84 61 3833 643
e-mail metecno_factory@hcm.fpt.vn
www.metecno.com